

Small Motorized Actuator

New ELMY®

INSTRUCTION MANUAL

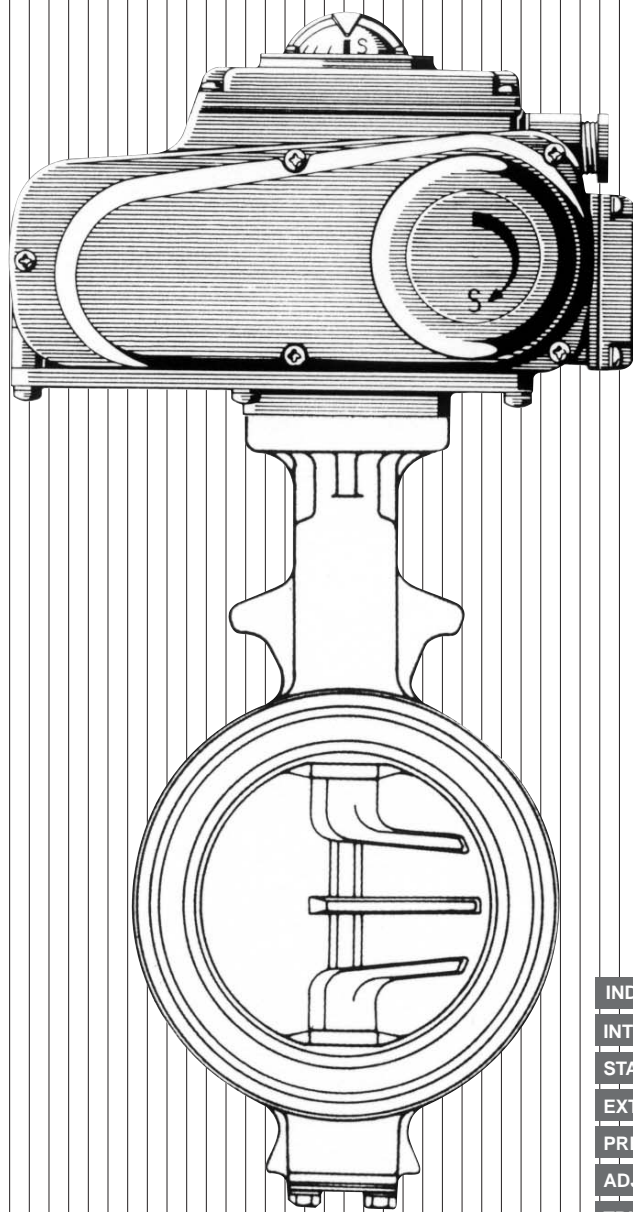

INDEX	Page
INTRODUCTION	1
STANDARD SPECIFICATIONS	1
EXTERNAL DIMENSIONS	2
PRECAUTIONS DURING INSTALLATION	3
ADJUSTMENT	7
TRIAL OPERATION	9
PRECAUTIONS BEFORE SERVICE	9
MAINTENANCE	10
TROUBLE SHOOTING	10

Introduction

This is an instruction manual for the New ELMY actuator, one of the best selling models of butterfly valve actuators, which has been improved in a number of key areas.

Operators of this actuator are expected to read through these instructions for the correct installation, operation, and maintenance.

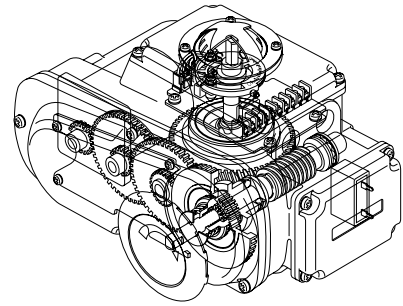



STANDARD SPECIFICATION

Type	Type 00	Type 0	Type 1	Type 2	Type 2.5	Type 3	Type 4
Output torque (N·m)	25	70	98	196	333	981 N	2000
Power source (V)	AC 100V, 200V, 220V		AC 100V, 120V, 200V, 220V, 240V, 50/60Hz ¹				
Motor capacity (W)	8		20	30		90	
Travel time (50/60Hz) (sec)	10/8	25/20 (180/150) ²		37/30 (260/210) ²		55/50 (500/440) ²	125/105 (1100/900) ²
Rating (min)	30						
Insulation	Class E						
Type of motor and its protective device	Reversible motor with built-in thermal protector						
Space heater	Option	Supplied under the standard specifications					
Position limit switch	One each at fully opened and closed positions, contact capacity: AC250V-5A (Can be used with minimum load down to 100mA.)	One each at fully opened and closed positions, contact capacity: AC250V-10A (Can be used with minimum load down to 100mA.)					
Torque limit switch	None						
Mechanical limit stop	End of travel positioning bolt built-in						
Conduit connections	G 1/2 (PF 1/2) 1 ports	G 1/2 (PF 1/2) 2 ports					
Enclosure	JIS C 0920 (IP 65), Class 5, dust and water-jet proof type						
Manual operation	Detachable handle			Declutchable handwheel			
Number of turns for handle/handwheel	7.5 turns	6.7 turns	16.5 turns				
Working temperature range	- 10 to 50 degreesC						
Storage temperature range	- 30 to 80 degreesC						
Paint finish	Epoxy-melanin baked with Munsell 2.5 BG 6/12						
Options	1) Space heater	1) Potentiometer: 135 and 500 2) Intermediate limit switch (no voltage) 3) Extra position limit switch contact capacity for minute-load: 30V-100mA (Can be used with minimum load down to 1mA.) 4) Servounit ¹ (AC 4 - 20mA, DC 1 - 5V, 0 - 10V) 5) Speed controller unit					

1. No space heater with servounit.
2. With speed controller unit

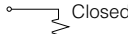
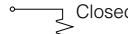
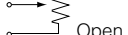
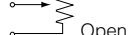
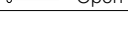
Terminal board (Type 0 to 4)

Terminal No.	Specification	Standard with extra position limit switches	With intermediate limit switches	With a potentiometer and extra position limit switches	With a potentiometer and intermediate limit switches
1	Heater				
2	COMMON				
3	Open switch				
4	Close switch				
5	Open lamp				
6	Close lamp				
11	Extra position limit switch, open end (intermediate limit switch 1) COMMON				
12	(intermediate limit switch 1) NC				
13	(intermediate limit switch 1) NO				
14	Extra position limit switch, close end (intermediate limit switch 2) COMMON				
15	(intermediate limit switch 2) NC				
16	(intermediate limit switch 2) NO				
17	Potentiometer	-	-		
18	Potentiometer	-	-		
19	Potentiometer	-	-		
20	Earth (F.G.)				

7, 8 and 9 are out of use.
: wired
- : not wired

EXTERNAL DIMENSIONS

Dimensions

Types 00 and 0

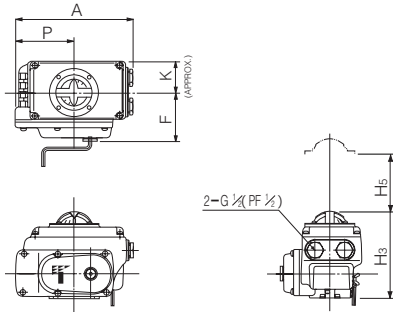

Type 1

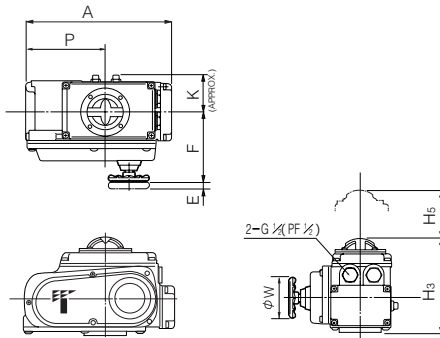

Types 2 and 2.5

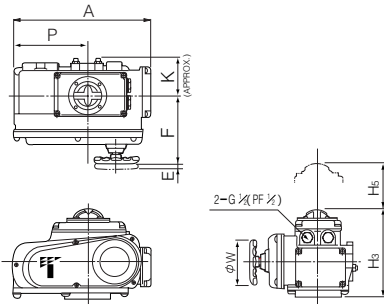

Types 3 and 4

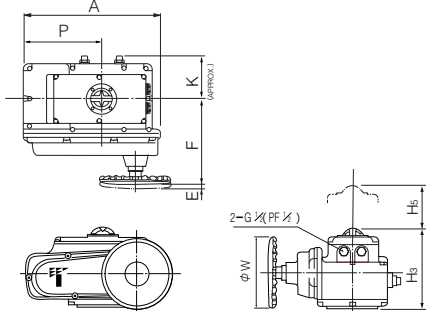

Dimensions / Weight

Motor type	Dimension (mm)								Approx. weight (kg)
	H ₃	H ₅	P	A	E	F	K	W	
Type 00	100	100	84	161	-	58	43	-	2.1
Type 0	150(185)	100	100	202	-	85	54	-	4.2
Type 1	165(191)	100	138	252	12	126	65	70	6.4
Type 2	198(224)	100	167	310	14	154	85	100	11.2
Type 2.5	198(224)	100	167	310	14	154	85	100	12.8
Type 3	230(255)	100	223	388	23	243	136	200	23.2
Type 4	230(255)	100	223	388	23	246	136	280	28.3

(): Dimension with servouint

Mounting details

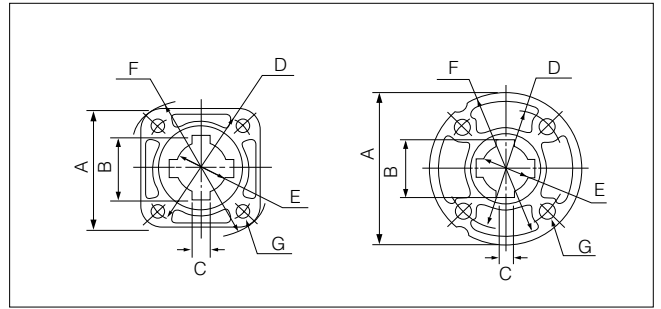

Mounting flange details

Actuator type	A	B	C	D ()	E ()	F ()	G				
							Qty	M	P	Dep.	
Type 00	ISO F05/F07	70	-	-	50/70	12	90	4	8	1.25	13
Type 0	ISO F07	70	-	-	70	12	90	4	8	1.25	13
Type 1	ISO F07	70	34.6	8	70	28	90	4	8	1.25	13
	Tomoe Original	100	34.6	8	80	28	100	4	10	1.5	12
Type 2	ISO F10	102	52.6	14	102	45	125	4	10	1.5	15
	Tomoe Original	125	52.6	14	95	45	125	4	12	1.75	15
Type 2.5	ISO F10	102	52.6	14	102	45	125	4	10	1.5	15
	ISO F12	125	52.6	14	125	45	155	4	12	1.75	20
	Tomoe Original	125	52.6	14	95	45	125	4	12	1.75	15
Type 3	ISO F10	140	57.6	14	102	50	175	4	10	1.5	15
	ISO F12	140	57.6	14	125	50	175	4	12	1.75	18
		140	38.6	10	140	32	175	4	12	1.75	18
	ISO F14	140	46.6	12	140	40	175	4	16	2.0	24
	Tomoe Original	200	43.1	10	125	35.5	200	4	12	1.75	24
		200	47.6	10	170	40	200	4	16	2.0	30
Type 4	ISO F12	140	57.6	14	125	50.0	175	4	12	1.75	18
		140	46.6	12	140	40.0	175	4	16	2.0	24
	ISO F14	140	53.6	14	140	46.0	175	4	16	2.0	24
		140	57.6	14	140	50.0	175	4	16	2.0	24
	Tomoe Original	200	47.6	10	170	40.0	200	4	16	2.0	30
		200	54.6	12	170	47.0	200	4	16	2.0	30

Tabel actuator selection

Nominal size (mm)	773Z	700G 705G 704G	700S 720F	731P	732P	732X	847T 846T	508V
40	Type 00	Type 00	-	-	-	-	-	-
50		Type 00	Type 00	Type 00	Type 00	Type 0	Type 0	
65		Type 0	Type 0	Type 0	Type 0	Type 1	Type 1	Type 1
80	Type 0	Type 1	Type 1	Type 1	Type 1	Type 1	Type 1	Type 1
100		Type 1	Type 1	Type 1	Type 1	Type 1	Type 1	Type 1
125	Type 1	Type 2	Type 2	Type 2	Type 2	Type 2	Type 2	Type 2
150		Type 2	Type 2	Type 2	Type 2	Type 2	Type 2	Type 2
200	Type 2	Type 2.5	Type 2.5	Type 2.5	Type 2.5	Type 2.5	Type 2.5	Type 2.5
250		Type 2.5	Type 2.5	Type 2.5	Type 2.5	Type 2.5	Type 2.5	Type 2.5
300	Type 2.5	Type 3	Type 3	Type 3	Type 3	Type 3	Type 3	Type 3
350		Type 3	Type 3	Type 3	Type 3	Type 3	Type 3	Type 3
400	Type 3	Type 3	Type 3	Type 3	Type 3	Type 3	Type 3	Type 3
450		Type 3	Type 3	Type 3	Type 3	Type 3	Type 3	Type 3
500		Type 3	Type 3	Type 3	Type 3	Type 3	Type 3	Type 3

PRECAUTIONS DURING INSTALLATION

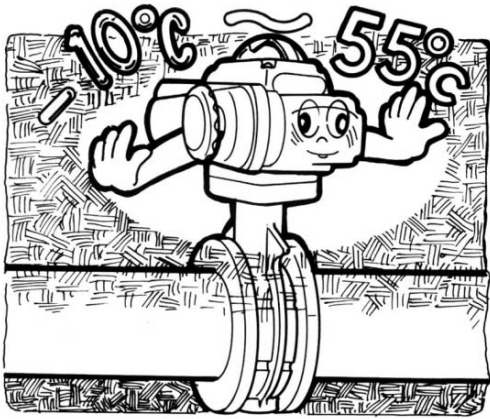

Installation site

- (1) The ambient temperature of an installation site should be kept between - 10 degrees C and +55 degrees C.
- (2) Any dangerous atmosphere should be kept out of the installation site.
- (3) Provide enough space for mounting/dismantling the cover of the electric cable terminals and allow reasonable access for future maintenance.

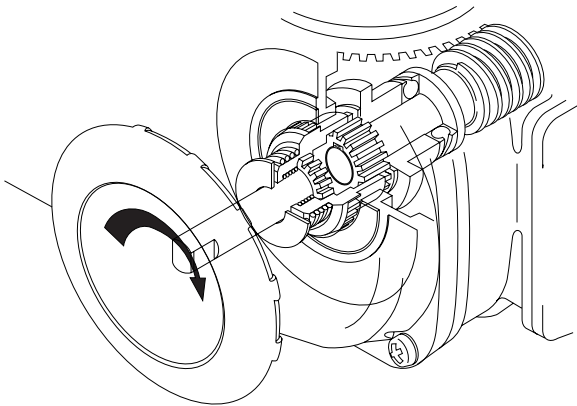

Mounting

- (1) Before mounting, operate the valve by hand and make sure that it moves freely. Then shut the valve.
- (2) Pull and turn the handwheel of the New ELMY till the indicator points to the "S" position.

A declutchable handwheel has been incorporated in the actuator for maximum safety and ease of operation. To disengage the clutch the handwheel is pulled out prior to turning. This allows the actuator to be turned manually and ensures safe operation in the event of the motor being energized. When released, the handwheel returns to the set position and the clutch is re-engaged.

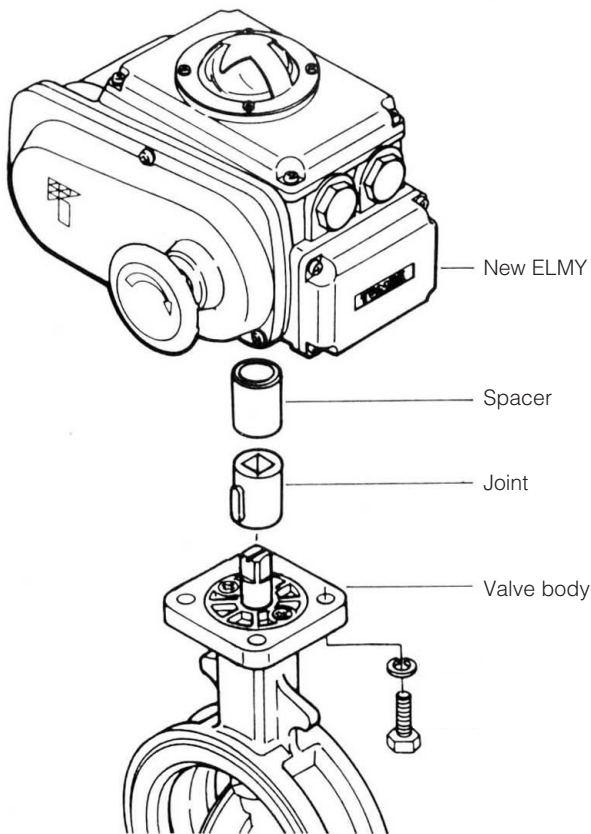

- (3) Install the joint and spacer on the valve stem.
- (4) Fasten the New ELMY to the baseplate with the four bolts.
- (5) Turn the handwheel of the New ELMY and see that it moves freely without any interference due to misalignment of the valve.

Cable connection

All control circuits are printed on a circuit board. A simple change of the board can meet a variety of optional control requirements. It allows easy wiring connections. The replaceable board, together with the employment of the modified limit switch cam device, permits a quick change in specification.

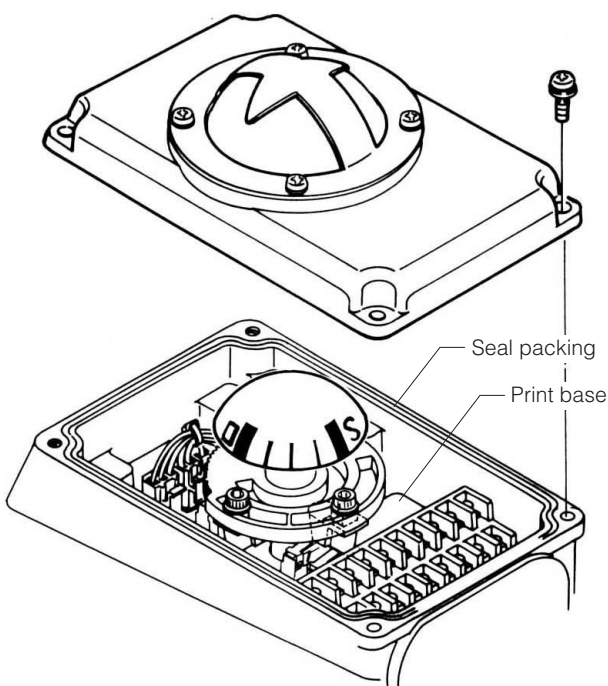

- (1) Wiring connections should be in accordance with the diagram attached on the inside of the top casing cover. On completion, check the wiring connections carefully.
- (2) The two conduit Connections should be sealed in a proper manner against water.
- (3) Every cover on the casing is sealed with an O-ring-style packing. Care should be taken not to cause any damage to the packing during disassembly or reassembly.

Wiring diagrams (Standard)

Type 00

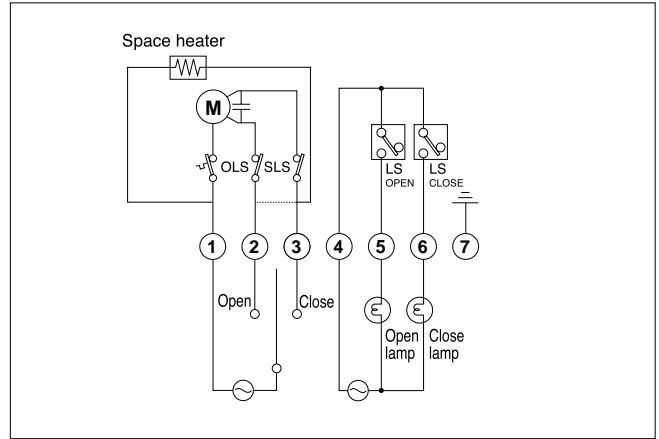

Type 0 to 4 Standard

With extra position limit switch (non-voltage)

Purpose

To send non-voltage full-open and full-closed signals by switching on and off.

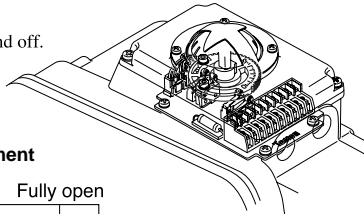

Limit switch contact development

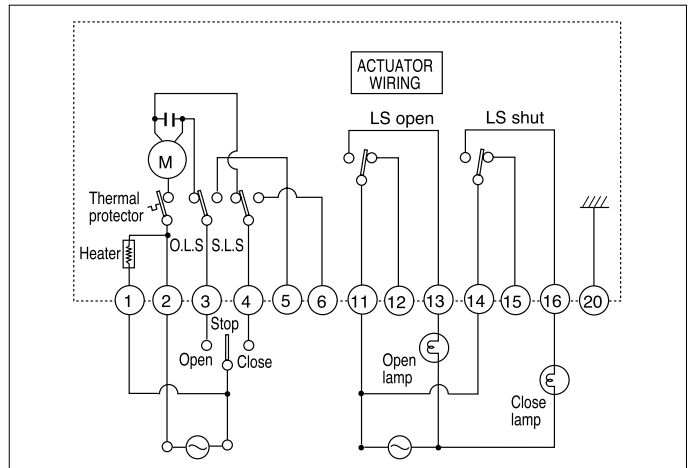
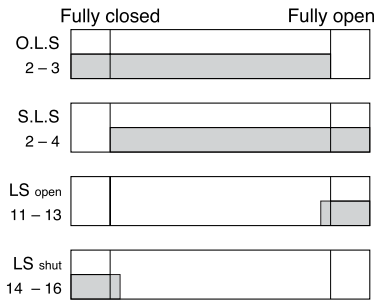

Notes

- Do not use a switch for two or more motor actuators, as the voltage will be transmitted to the other motor through the capacitor and cause malfunction.
- Extra limit switches work 2 to 3% ahead of each opening and closing position of the valve. Therefore, if you stop the valve using signals from an extra limit switch, leakage may occur.
- The contact capacity of the extra limit switch is 250 VAC-10 A (min. 0.1 A). For anything below this contact capacity (1 mA to 100 mA, 5 to 30 V), please use specifications for minute loads.

Wiring diagrams (Type 0 to 4) (Option)

With intermediate limit switch

Purpose

To send intermediate open and close signals by switching on and off, and to stop the valve at intermediate positions.

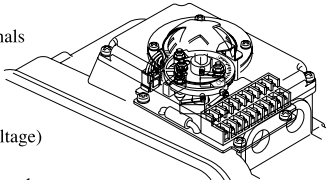

Options

Intermediate limit switches (two, non-voltage)

Limit switch contact development

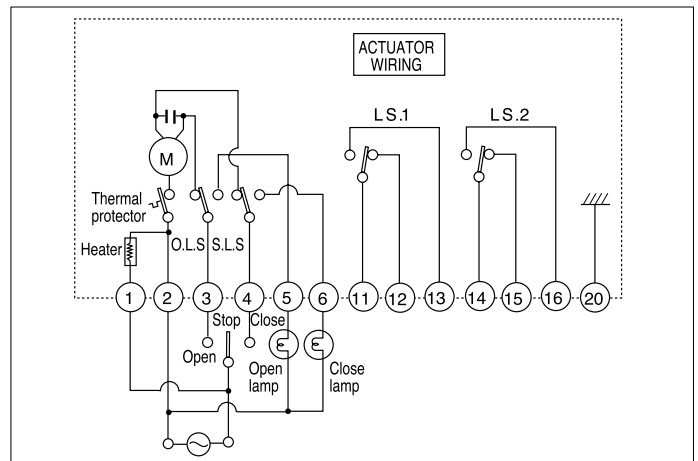
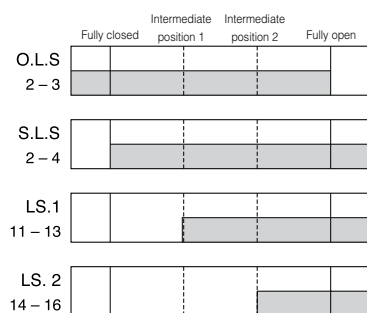

Notes

- Do not use a switch for two or more motor actuators, as the voltage will be transmitted to the other motor through the capacitor and cause malfunction.
- The contact capacity of the extra limit switch is 250 VAC-10 A (min. 0.1 A). For anything below this contact capacity (1 mA to 100 mA, 5 to 30 V), please use specifications for minute loads.

Wiring diagrams (Type 0 to 4) (Option)

With potentiometer and extra position limit switch (non-voltage)

Purpose

To control valve opening by resistance variations and send non-voltage full-open and full-closed signals by switching on and off.

Options

135 or 500 potentiometer

Limit switch contact development

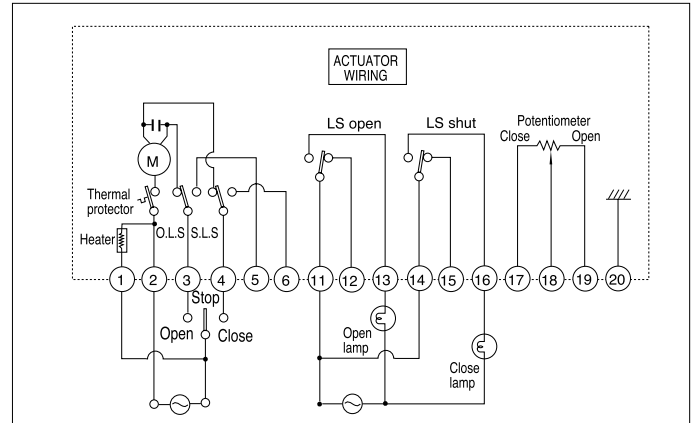
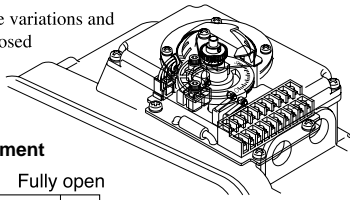
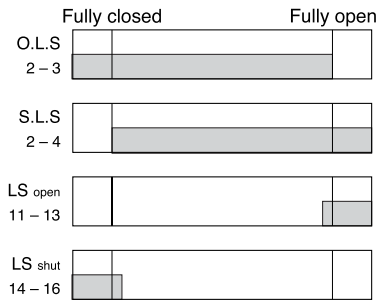

Notes

- Do not use a switch for two or more of motor actuators, as the voltage will be transmitted to the other motor through the capacitor and cause malfunction.
- Extra limit switches work 2 to 3% ahead of each opening and closing position of the valve. Therefore, if you stop the valve using signals from an extra limit switch, leakage may occur.
- The contact capacity of the extra limit switch is 250 VAC-10 A (min. 0.1 A). For anything below this contact capacity (1 mA to 100 mA, 5 to 30 V), please use specifications for minute loads.

With thermal output

Limit switch contact development

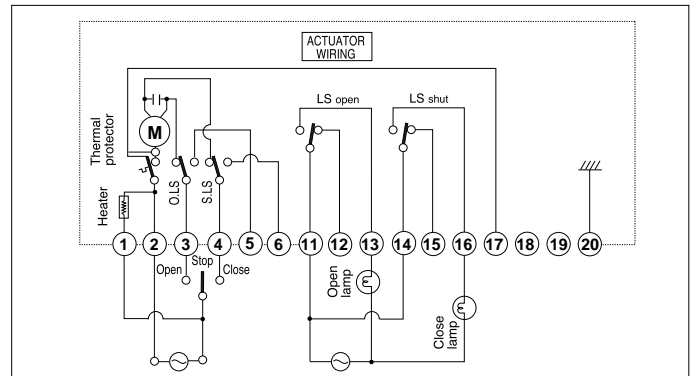
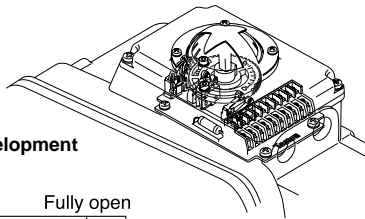
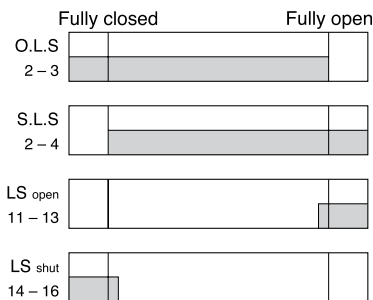

Notes

- Outputs when thermal operation shall be "b" contacts.
- Do not use a switch for two or more motor actuators, as the voltage will be transmitted to the other motor through the capacitor and cause malfunction.
- Extra limit switches work 2 to 3% ahead of each opening and closing position of the valve. Therefore, if you stop the valve using signals from an extra limit switch, leakage may occur.
- The contact capacity of the extra limit switch is 250 VAC-10 A (min. 0.1 A). For anything below this contact capacity (1 mA to 100 mA, 5 to 30 V), please use specifications for minute loads.

With servo unit, potentiometer and extra position limit switch (non-voltage)

Purpose

Input signal when valve opening proportionally controlled for input signal 4 to 20mA DC (1 to 5 V DC and 0 to 10 V DC optional) output 4 to 20mA DC signal and full-open/full-close contact output.

Options

Servo unit
Potentiometer 500

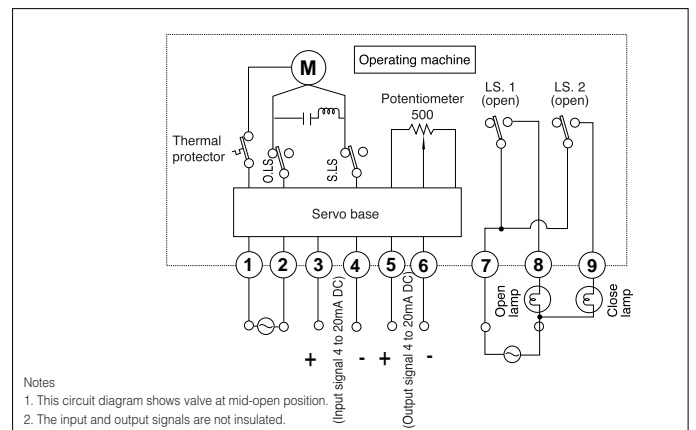
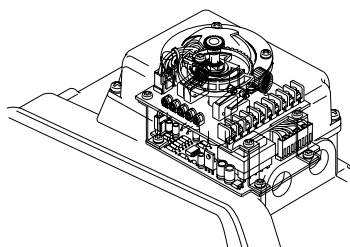

Notes

- This circuit diagram shows valve at mid-open position.
- The input and output signals are not insulated.

Notes

- The contact capacity of the spare open/close limit switch is 250 V AC, 10 A (0.1 A minimum). When below this contact capacity (1mA to 100mA, 5 to 30 V), please use the minimal load specification.

ADJUSTMENT

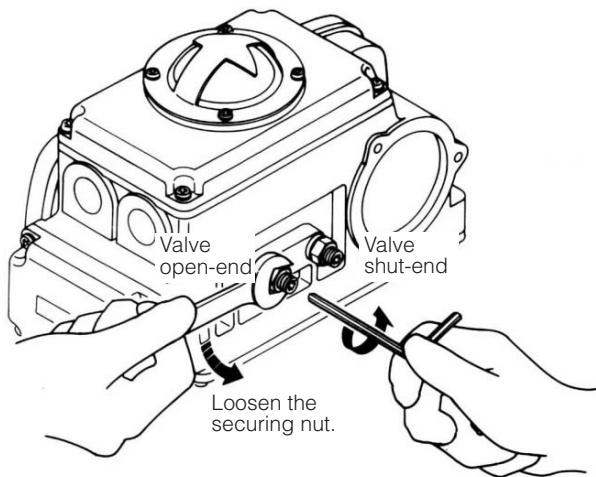

(1) The new limit switch cam mechanism has a unique device that permits easy on site adjustment at the top of the actuator. It also have a gear that allows a potentiometer to be added, if required.

(2) Before the adjustment of a position limit switch, release the lock nut on the locking bolt and then unwind the locking bolt with 4 to 5 turns. The limit switch is adjusted at our factory prior to shipment.

Adjusting the limit switch

- (1) First, remove the top cover and pull out the indicator.
- (2) Slightly loosen the cap bolt of the limit switch striker with an Allen wrench.
- (3) Now, the limit switch strikers is ready to be moved in or out. Turn it with the screw driver clockwise to move it in, and counterclockwise to move it out.
- (4) Tighten the lock nut when the striker is in the required position.
- (5) Make sure that the limit switch operates at the correct position.

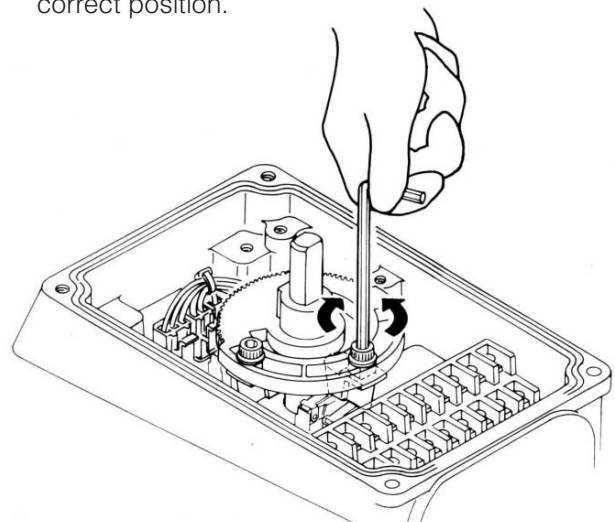
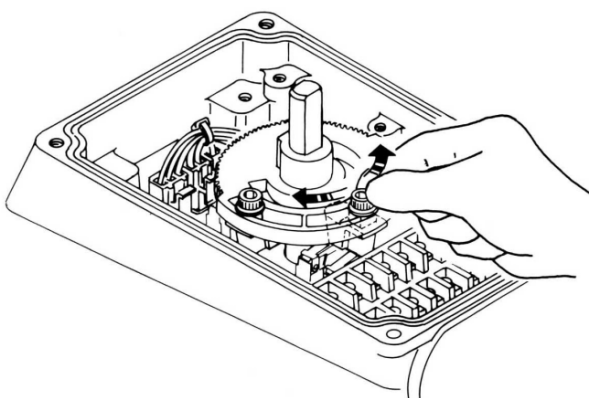
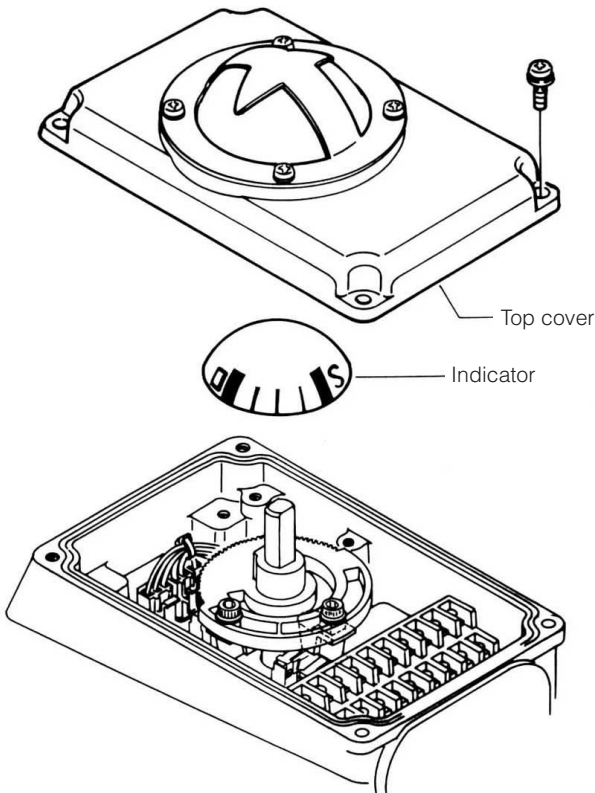

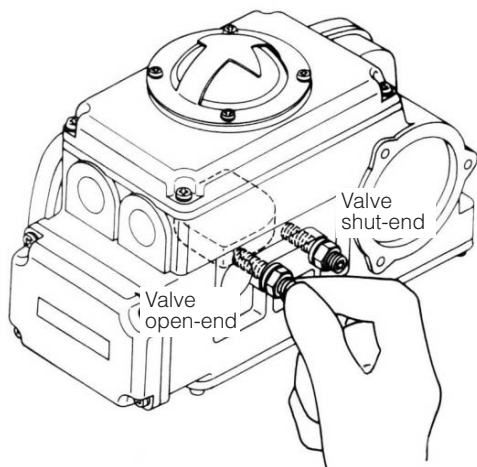

(6) On completion of the adjustment, turn the mechanical limit stop bolt by hand until it touches the projection on the worm wheel, then turn it back by one half to one turn. Fasten the lock nut of the stop bolt.

It should be kept in mind that the limit stop bolt should not interfere with the movement of the gears until after limit switch makes contact. Incorrect setting of the limit stop bolt may result in overheating of the motor.

Caution:

Except for the top cover, all the screws that fix the covers are applied with a viscous agent to prevent the screws from loosening. For dismantling, carefully release the screws without causing damage to their heads.

Apply the screw with a viscous agent when reassembling.

Adjustment of actuator (NEL with servo unit) (Type 0 to 4)

- (1) Set the actuator in close position.
- (2) Measure the resistance on the contact of PT(3p) of connector plug for potentiometer on limit switch board. Then, fix the resistance value between 1(green)-2(white) to 10 to 15 .
- (3) Fix the potentiometer gear and confirm the resistance value.

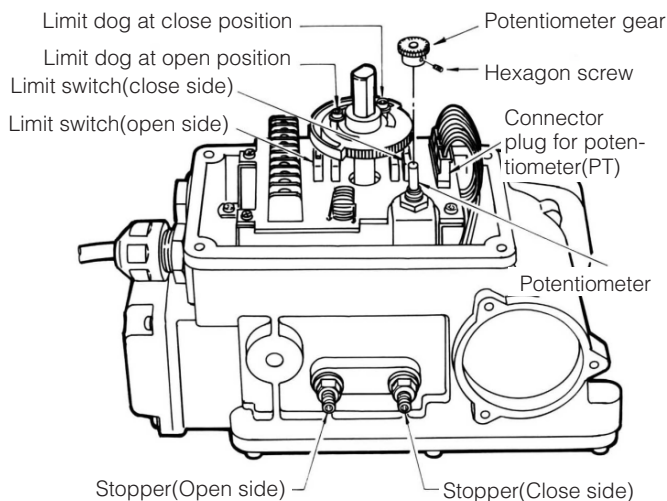

- (4) Fix the limit dog to make it act on close side (outside)
- (5) Electrify the actuator and make it move to open side by Z1 volume. Then, make it move to close position gradually by Z1 volume and stop at limit switch position.
- (6) Fix output signal at 4mA CD \pm 1% by Z2 volume.
- (7) Put input signal at 12mA, adjust it at 50% opening by S1 volume.
- (8) Put input signal at 20mA. Fix the dog of open limit switch at 100%.
- (9) Fix output signal at 20mA DC \pm 1% by S2 volume.
- (10) Make the open side stopper bolt touch with the stopper. Then, fix it at a half turn before the stop position.

- (11) Make the close side stopper bolt touch with the stopper, Then fix it at a half turn before the stop position.
- (12) Open / close it twice and make sure stop positions at both open / close side and output signal

TRIAL OPERATION

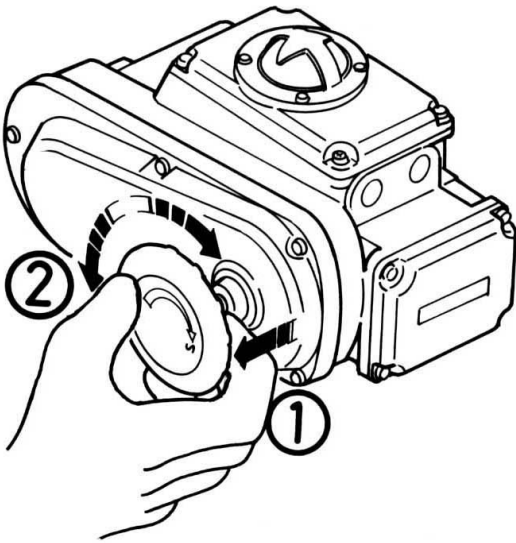

Manual operation

- (1) ① Pull the handwheel and ② turn it in either direction, When released, it springs back.
- (2) Turn the handwheel clockwise to shut the valve. Turn the handwheel counterclockwise to open the valve.

Caution:

An excessive turn will result in a failure of the stopper or other components, Watch the position indicator and do not turn beyond the OPEN or SHUT position.

Operation by motor

- (1) Before operation, make sure that the “O” and “S” on the position indicator match exactly the open / shut positions of the valve.
- (2) Ensure that the OPEN push button opens the valve, and the SHUT push button shuts it.
- (3) Ensure that the valve stops at its predetermined OPEN and SHUT positions.

PRECAUTIONS BEFORE SERVICE

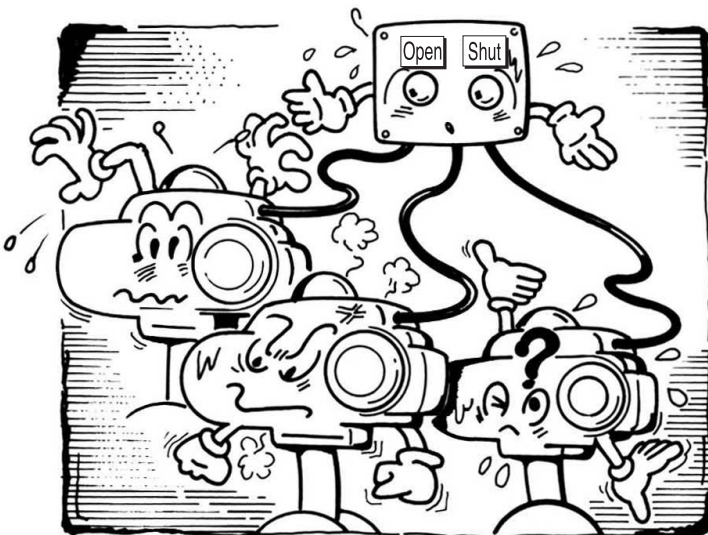

- (1) Each New ELMY should be controlled by one circuit breaker or relay. If two or more New ELMY's are controlled by one circuit breaker, they may sometimes actuate erroneously due to a loop circuit.
- (2) The New ELMY with a potentiometer should not be put into service for regulation of pressure, liquid level, and other operational parameters which usually require a continuous control. In such cases, our “MICOM ELMY” which has been developed for control purposes is the optimum actuator.
- (3) Signal circuits (for a potentiometer, input / output signals, etc.) should be strictly separated from power cables and high tension cables.

MAINTENANCE

Lubrication

- (1) The New ELMY is lubricated with molybdenum bisulphate compound which has a long-life and anti-pressure characteristics. Therefore, no lubrication is required.

Periodical operation

- (1) If the New ELMY is to be out of service for a long period, it should be operated periodically, say once a week, to keep it free.

TROUBLE SHOOTING

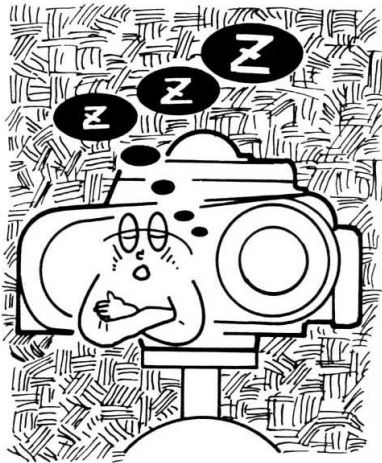
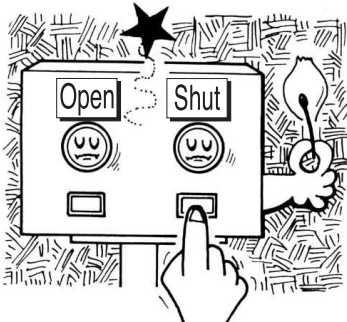
Troubles	Cause of trouble	Solution
<p>No start.</p> 	No power.	Put on the power.
	Cables disconnected.	Replace the cables.
	Terminals out of place.	Connect the terminals with the right mode.
	Low voltage or improper power source.	Check the voltage with an instrument.
	The thermal protector has tripped.	Cool down the ambient temp. Avoid too much repeated operation.
	The phase advance capacitor failed.	Replace the capacitor.
<p>No signal light on.</p> 	The lights not indicating.	Replace the lights.
	Limit switch failure.	Replace limit switches.
	Misalignment of the stoppers.	Realign the stoppers.

The specifications are subject to change without notice. Please consult us for the latest specifications.
All copy rights reserved.

TOMOE VALVE CO.,LTD. www.tomoevalve.com

Head Office
3-11-11 Shinmachi, Nishi-ku, Osaka 550-0013, Japan
Telephone: 81-6-6110-2101/2102/2103 Telefax: 81-6-6110-2105/2106 E-mail:sales@tomoevalve.com

Global Sales Operations

TOMOE VALVE ASIA PACIFIC PTE.LTD.

Blk 8 Chia Ping Road #07-11 Singapore 619973
Telephone: 65-68995060 Telefax: 65-68995061 E-mail:sales@tomoe.com.sg

TOMOE VALVE LIMITED www.tomoeurope.co.uk

Clearwater Road, Queensway Meadows Industrial Estate,
Newport, South Wales NP19 4ST, United Kingdom
Telephone: 44-1633-636800 Telefax: 44-1633-636801 E-mail:sales@tomoevalve.co.uk
sales@tomotrtec.co.uk

TOMOE VALVE CORPORATION

600, Rockmead Drive Suite 115,
Kingwood, Houston Texas, 77339, USA
Telephone: 001-281-358-7571/7859 Telefax: 001-281-358-7861

Regional Office : Abu Dhabi, Dubai