

# Teflon<sup>®</sup> Lining Valve

846T/847T

841T/842T

## INSTRUCTION MANUAL

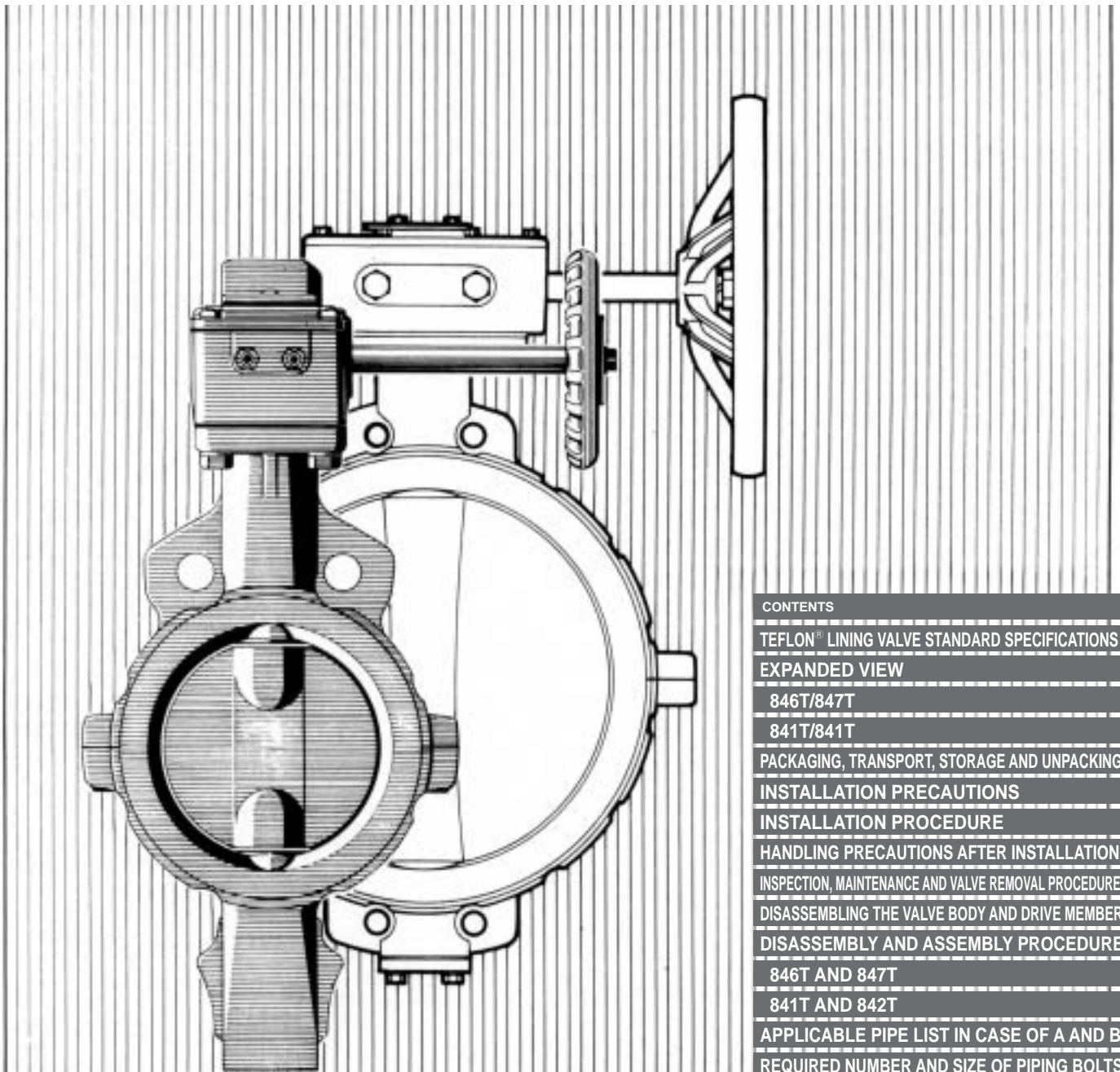

CONTENTS	Page
TEFLON <sup>®</sup> LINING VALVE STANDARD SPECIFICATIONS	2
EXPANDED VIEW	
846T/847T	3
841T/842T	4
PACKAGING, TRANSPORT, STORAGE AND UNPACKING	5
INSTALLATION PRECAUTIONS	6
INSTALLATION PROCEDURE	9
HANDLING PRECAUTIONS AFTER INSTALLATION	11
INSPECTION, MAINTENANCE AND VALVE REMOVAL PROCEDURE	12
DISASSEMBLING THE VALVE BODY AND DRIVE MEMBER	13
DISASSEMBLY AND ASSEMBLY PROCEDURE	
846T AND 847T	16
841T AND 842T	24
APPLICABLE PIPE LIST IN CASE OF A AND B	27
REQUIRED NUMBER AND SIZE OF PIPING BOLTS	28
PIPING GASKET	29
TROUBLESHOOTING	30

This instruction manual explains standard usage of the Teflon<sup>®</sup> Lining Valve series. For details on using a drive member, please refer to the manual for a specific drive member.

We will indicate level of danger caused by neglecting these cautions as the following

 <b>CAUTION</b>	this mark indicates possibility of serious injury to personnels or damage to components
---	---

# TEFLON® LINING VALVE STANDARD SPECIFICATIONS

Valve type		846T	847T
Body shape (Connection)		Wafer type	Wafer type
Valve nominal size		65mm to 200mm	50mm to 300mm
Flange accommodation		JIS 5K/10K, ANSI 125Lb/150Lb, etc	JIS 5K/10K, ANSI 125Lb/150Lb, etc
Face-to-face dimensions		JIS B2002 (46 series)/ ISO 5752 wafer butterfly valve (short)	JIS B2002 (46 series)/ ISO 5752 wafer butterfly valve (short)
Max. working pressure		1.0MPa	1.0MPa
Service temperature		PPS disc: - 20 to 120 degrees C, SCS disc: - 20 to 200 degrees C	- 20 to 200 degrees C
Allowable temperature in continuous use		PPS disc: 0 to 80 degrees C, SCS disc: 0 to 150 degrees C	0 to 150 degrees C
Standard materials	Body	FCD-S	FCD-S
	Disc	PPS, SCS14	SCS13 with PFA lining: 50 to 200 mm SCS13 with PTFE lining: 250 mm and 300 mm
	Stem	SUS316 (sealing: PFA lining)	SUS420J2 (sealing: PFA lining)
	Seat ring	PFA (Back-up rubber: fluorocarbon rubber)	PFA: 50 to 200 mm, PTFE: 250 mm and 300 mm (Back-up rubber: fluorocarbon rubber)

Valve type		841T	842T
Body shape (Connection)		Wafer type	Wafer type
Valve nominal size		250mm to 600mm	350mm to 600mm
Flange accommodation		JIS 10K, ANSI 150Lb, etc	JIS 10K, ANSI 150Lb, etc
Face-to-face dimensions		Manufactured standard	Manufactured standard
Max. working pressure		0.7MPa	0.7MPa
Service temperature		- 10 to 100 degrees C	- 10 to 100 degrees C
Allowable temperature in continuous use		0 to 90 degrees C	0 to 90 degrees C
Standard materials	Body	FCD-S	FCD-S
	Disc	SCS14	FCD-S with PTFE lining
	Stem	SUS316	S45C with FEP coating
	Seat ring	PTFE (Back-up rubber: CR)	PTFE (Back-up rubber: CR)

Remark: For details, see "GENERAL CATALOG".

# 846T/847T

## Expanded View

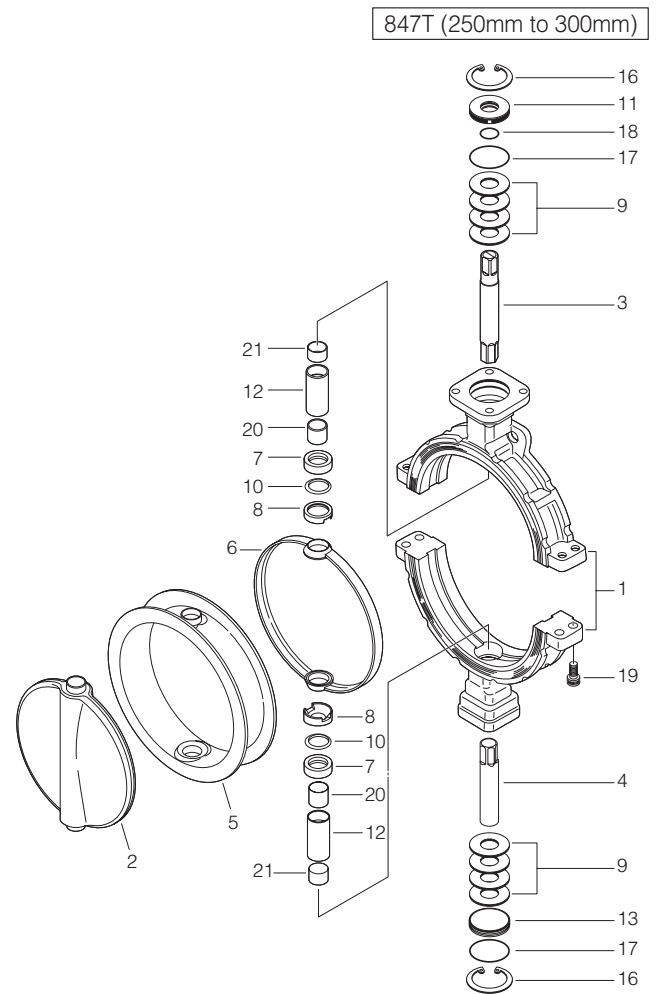
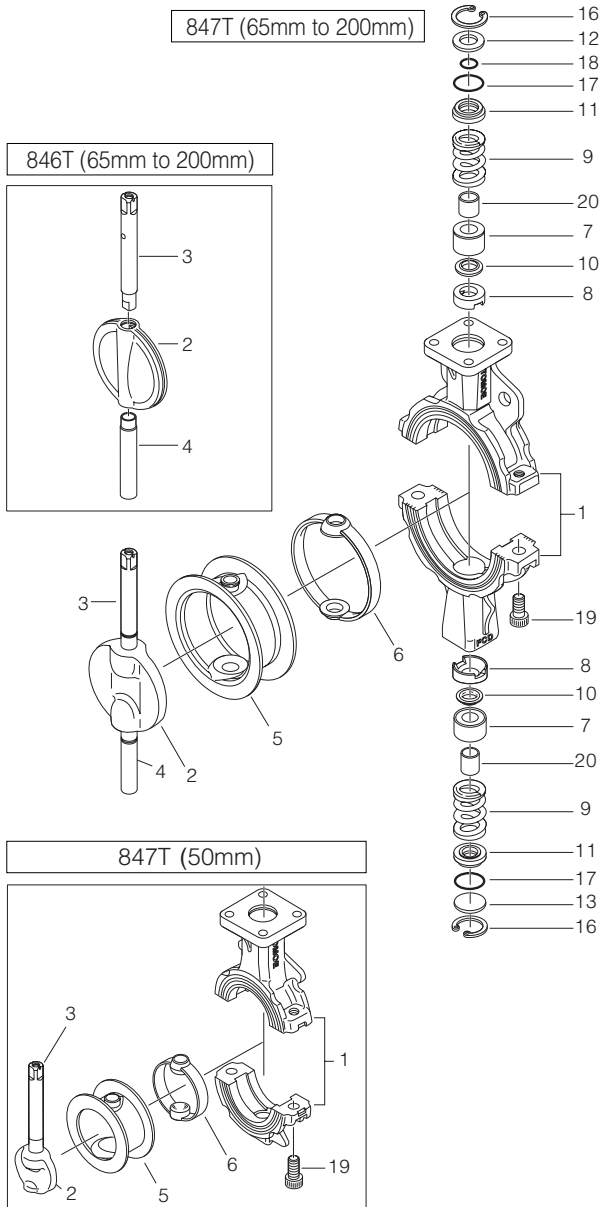

**846T/847T Parts list (846T: 65 to 200mm, 847T: 50 to 200mm)**

No.	Description	Q'ty	Remarks
1	Body	1	
2	Disc	1	
3	Upper stem	1	
4	Lower stem	1	
5	Seat ring	1	See Remark 2.
6	Back-up rubber	1	See Remark 2.
7	Bearing	1	50mm
		2	65mm to 200mm
8	Secondary ring	1	50mm
		2	65mm to 200mm
9	Spring	1	50mm
		2	65mm to 200mm
10	Gland packing	1	50mm
		2	65mm to 200mm
11	Dust seal	1	50mm
		2	65mm to 200mm
12	Retaining spring	1	
13	Bottom cover	1	65mm to 200mm
16	C-shape retaining ring	1	50mm
		2	65mm to 200mm
17	"O"ring	1	50mm
		2	65mm to 200mm
18	"O"ring	1	
19	Hexagon hole bolt	2	50mm to 150mm
		4	200mm
20	Bearing	1	50mm
		2	65mm to 200mm

**847T Parts list (250mm, 300mm)**

No.	Description	Q'ty	Remarks
1	Body	1	
2	Disc	1	
3	Upper stem	1	
4	Lower stem	1	
5	Seat ring	1	
6	Back-up rubber	1	
7	Bearing	2	
8	Secondary ring	2	
9	Spring	8	
10	Gland packing	2	
11	Dust seal	1	
12	Bearing	2	
13	Bottom cover	1	
16	C-shape retaining ring	2	
17	"O"ring	2	
18	"O"ring	1	
19	Hexagon hole bolt	2	250mm
		4	300mm
20	Bearing	2	
21	Bearing	2	

Remark 1: The indicates recommended spare parts. They are supplied as "Seat ring set" with a small hexagonal spanner to remove set screws.

Remark 2: Item number 5 (seating) and 6 (back-up rubber) are supplied as a set. For 847T type, item number 2 (disc), 3 (upper stem) and 4 (lower stem) are supplied as an assembled unit.

# 841T/842T

## Expanded View

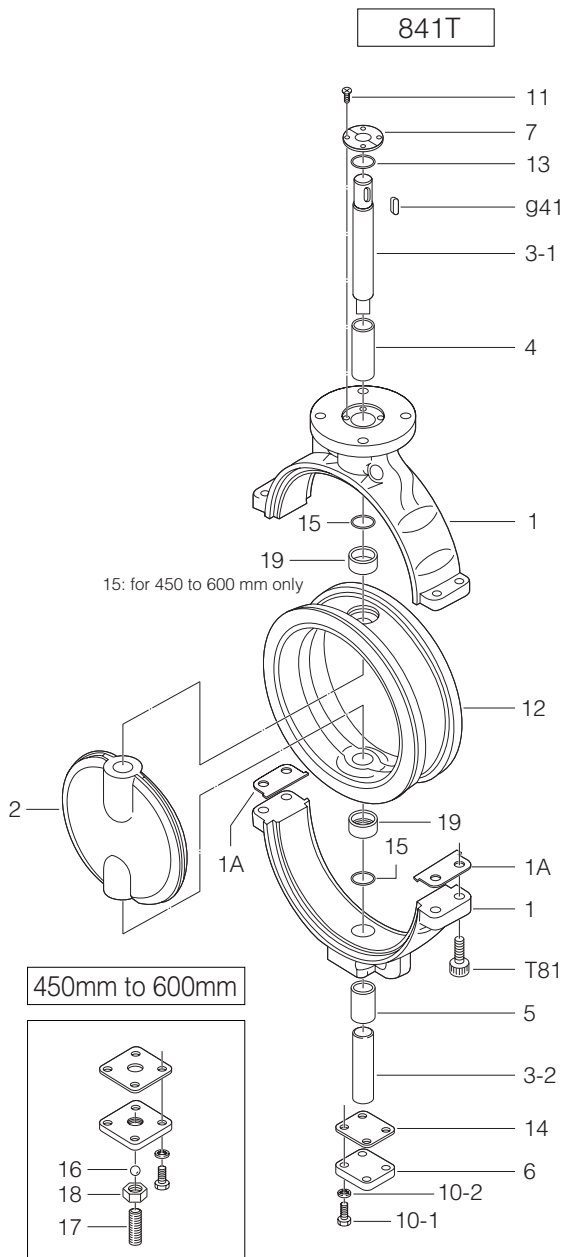

### 841T Parts list

No.	Description	Q'ty	Remarks
1	Body	1	
1A	Packing	2	
2	Disc	1	
3-1	Upper stem	1	
3-2	Lower stem	1	
4	Bushing	1	
5	Bushing	1	
6	Bottom cover	1	
7	Retainer plate	1 Set	
10-1	Hexagon bolt	4	
10-2	Spring washer	4	
11	Machine screw	4	
12	Seat ring	1	
13	"O"ring	1	
14	Gasket	1	
15	"O"ring	2	Only 450mm to 600mm
16	Ball	1	Only 450mm to 600mm
17	Hollow bolt	1	Only 450mm to 600mm
18	Lock nut	1	Only 450mm to 600mm
19	Back-up ring	2	Only 450mm to 600mm
T81	Hexagon hole bolt	4	
g41	Key	1	

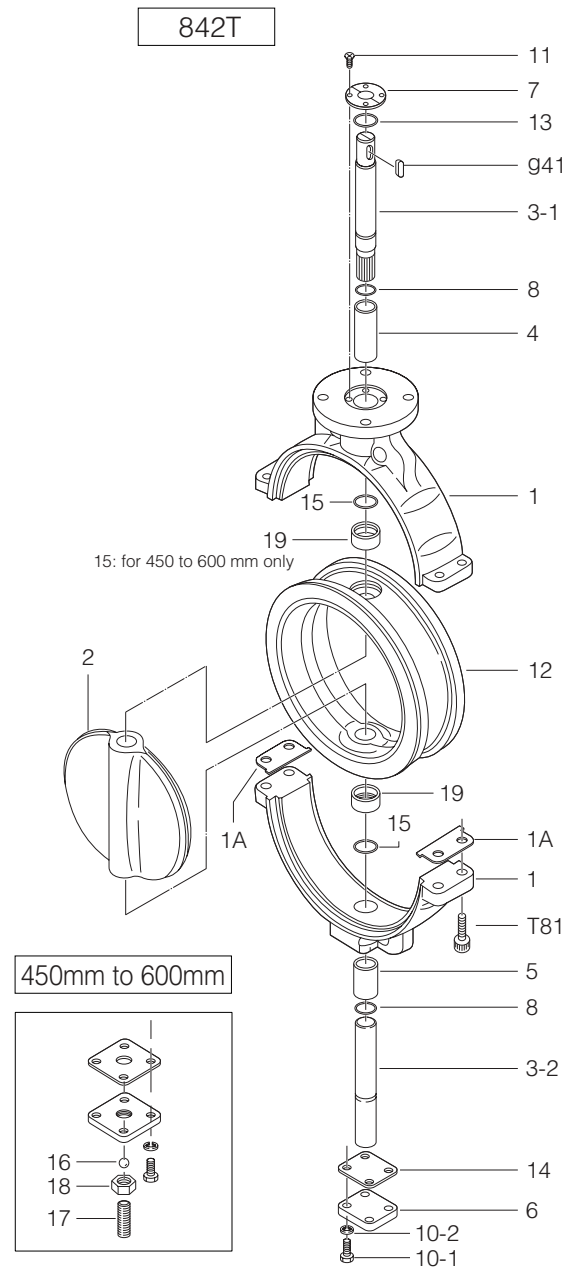

### 842T Parts list

No.	Description	Q'ty	Remarks
1	Body	1	
1A	Packing	2	
2	Disc	1	
3-1	Upper stem	1	
3-2	Lower stem	1	
4	Bushing	1	
5	Bushing	1	
6	Bottom cover	1	
7	Retainer plate	1 Set	
8	"O"ring	2	
10-1	Hexagon bolt	4	
10-2	Spring washer	4	
11	Machine screw	4	
12	Seat ring	1	
13	"O"ring	1	
14	Gasket	1	
15	"O"ring	2	Only 450mm to 600mm
16	Ball	1	Only 450mm to 600mm
17	Hollow bolt	1	Only 450mm to 600mm
18	Lock nut	1	Only 450mm to 600mm
19	Back-up ring	2	Only 450mm to 600mm
T81	Hexagon hole bolt	4	
g41	Key	1	

Remark: The **g41** indicates recommended spare parts. They are supplied as "Seat ring set" with a small hexagonal spanner to remove set screws.

## PACKAGING

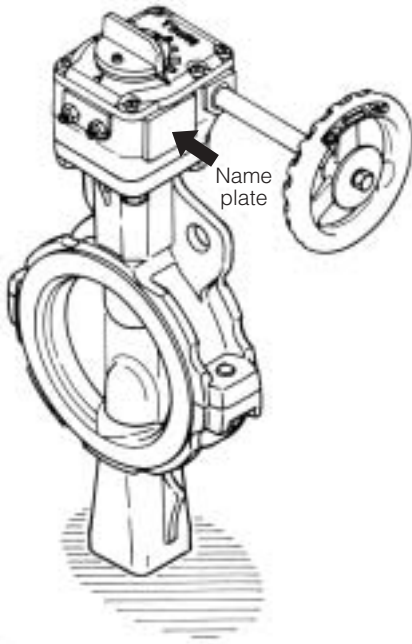

(Fig. 1)

- (1) For 50 to 200 mm types, standard gear type and lever type off-the-shelf products are packed in cardboard or wooden boxes.
- (2) The valve is kept open about 10 ° from its closed position when shipped.
- (3) The valve has a nameplate with which you can verify information such as the nominal size and material. (Fig. 1)  
(For lock lever type, this information is provided on the indicator.)

## TRANSPORT

- (1) Use containers for ocean transport.
- (2) Use a covered vehicle for inland transport. If an uncovered vehicle is used, be sure to cover the valves with a protective tarp.

## STORAGE

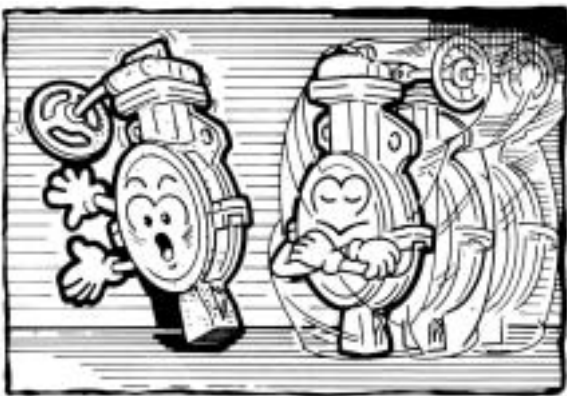

(Fig. 2)

- (1) When storing valves, keep them indoors in as cool and dark a place as possible (temperature: -10 to +60 degrees C, humidity: 70 % or less ) without removing the cardboard packaging or the protective plate attached to the valve.
- (2) PFA and PTFE are very easy to scratch; therefore, do not unpack until immediately before valve installation.
- (3) Operate the valve once every three months.
- (4) When storing unpackaged butterfly valves, make sure that no unreasonable load is being applied to the valve body and drive member. (Fig. 2)

## UNPACKING

- (1) Unpack the valve immediately before installing it into the piping. Do not leave the valve unpacked for long periods of time.

# INSTALLATION PRECAUTIONS

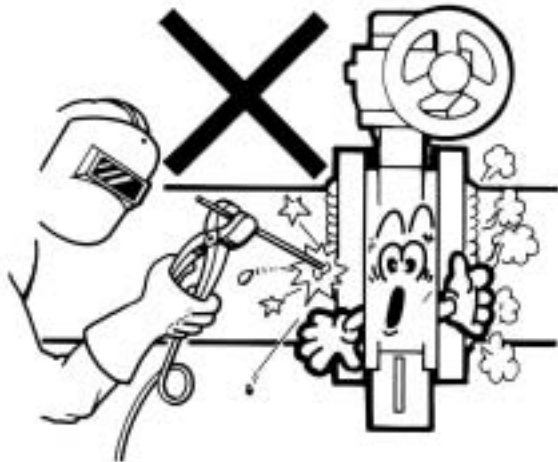

(Fig. 3)

- (1) Install after verifying the material of the valve seat ring and disc.
- (2) Installation of the valve immediately after welding the pipe flange will lead to adverse consequences, such as damage to the seat ring. Make sure that the temperature has cooled sufficiently and that you have removed weld spatter before installing the valve. Never weld when the valve is in the piping. (Fig. 3)
- (3) The seat ring might become damaged or the flange may leak if the flange face that contacts the valve seat ring is as shown in Fig. 4. Also, please confirm that there is no distortion to the flange or that there is no damage, such as scratches, to the flange face.

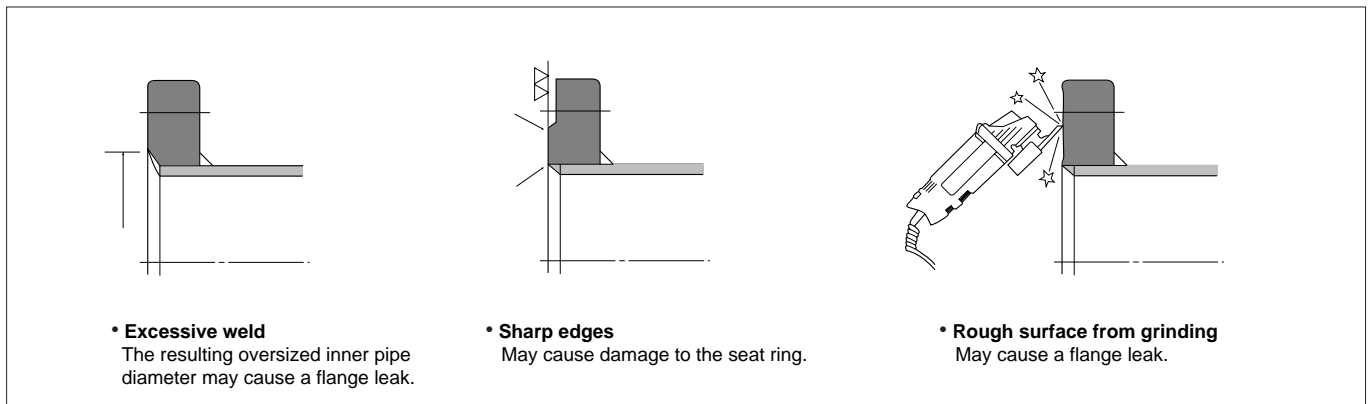

(Fig. 4)

- (4) 846T and 847T are constructed so that piping gaskets are not necessary. If the flange face is warped, scratched, has remaining irregularities, or is otherwise not sufficiently flat, we recommend using a piping gasket in order to prevent scratching of the seat ring. However, do not use rubber gaskets as these can cause faulty operation. (Off-the-shelf products can be used.) You must use piping gaskets with the 841T and 842T. However, do not use rubber gaskets as these can cause faulty operation. Also, valves with special dimensions are sometimes required. For these, please refer to the piping gasket table on page 29.
- (5) Do not apply strong shock such as by throwing the valve and do not put objects or put your weight on the lever or handwheel.

## INSTALLATION PRECAUTIONS

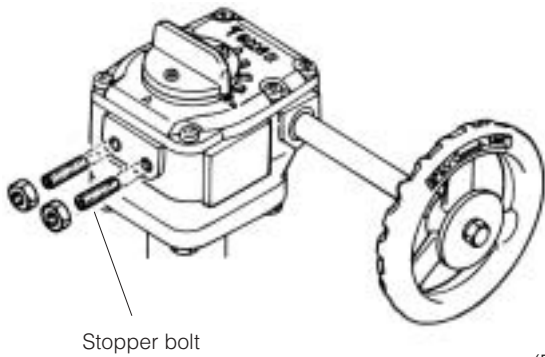

(Fig. 5)

(6) Do not touch the stopper bolts on the gear box.  
Changing the valve close position will cause valve seat leakage. (Fig. 5)

(7) Alignment of the valve to the flange should be done accurately.

In case the set bolt holes are tapped:

Never install the valve to one flange side using the tap holes for the four setting bolts located at the top and bottom of the valve body. The setting bolts are used for piping alignment. Tighten the setting bolts after completely securing the valve with the long bolts.

(8) Before tightening the piping bolts, check that the disc does not touch the inside of the flange when the valve is open.

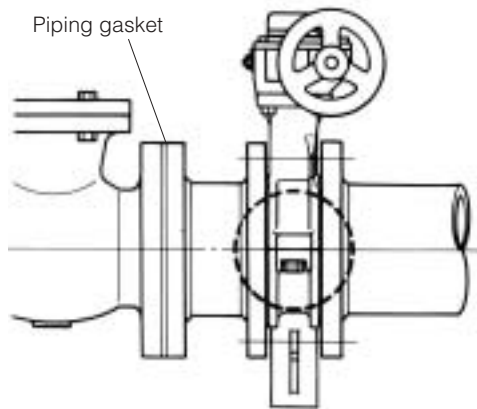

(Fig. 6)

(9) When installing a non-return valve, pump or flexible rubber joint with a butterfly valve, always insert a short pipe in between. Not doing so will cause the disc to hit during operation and lead to faulty operation. (Fig. 6)

(10) When installing a resin pipe with tapered core, use one that has a collar and whose internal diameter is more than that of the pipe internal diameters given on page 27.

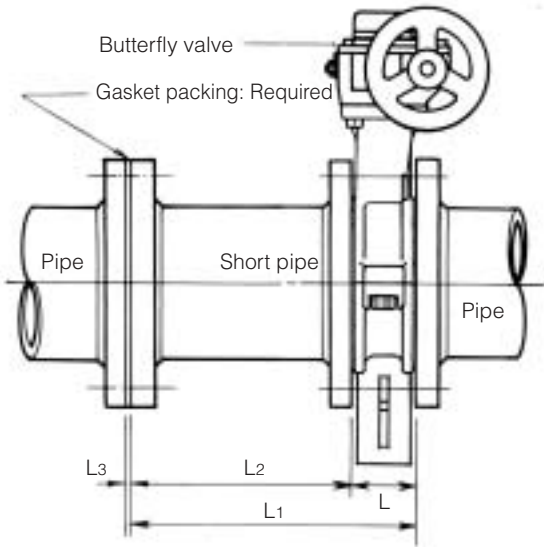

(Fig. 7)

(11) When replacing a previously installed regular valve with a butterfly valve, since the face-to-face dimension of the previously installed valve will be greater, you must insert a short pipe and adjust to the face-to-face dimension of the original valve pipe flange. Use the equation below when making the short pipe. (Fig. 7)

**Length of short pipe**

$L_2 = L_1 - L$	mm
$L_2$ : Length of short pipe	mm
$L_1$ : Face-to-face dimension of existing valve	mm
$L$ : Face-to-face dimension of TOMOE butterfly valve	mm

(12) Although it is okay to install a valve in the direction that makes installation easy, please take caution in the following conditions.

- 1 Valves with nominal diameters 450 mm and above have steel balls at the lower end of the stems; therefore, make sure that the actuator does not face downward (relative to horizontal).
- 2 Be careful of the stem direction when piping conditions are as shown in Fig. 8.

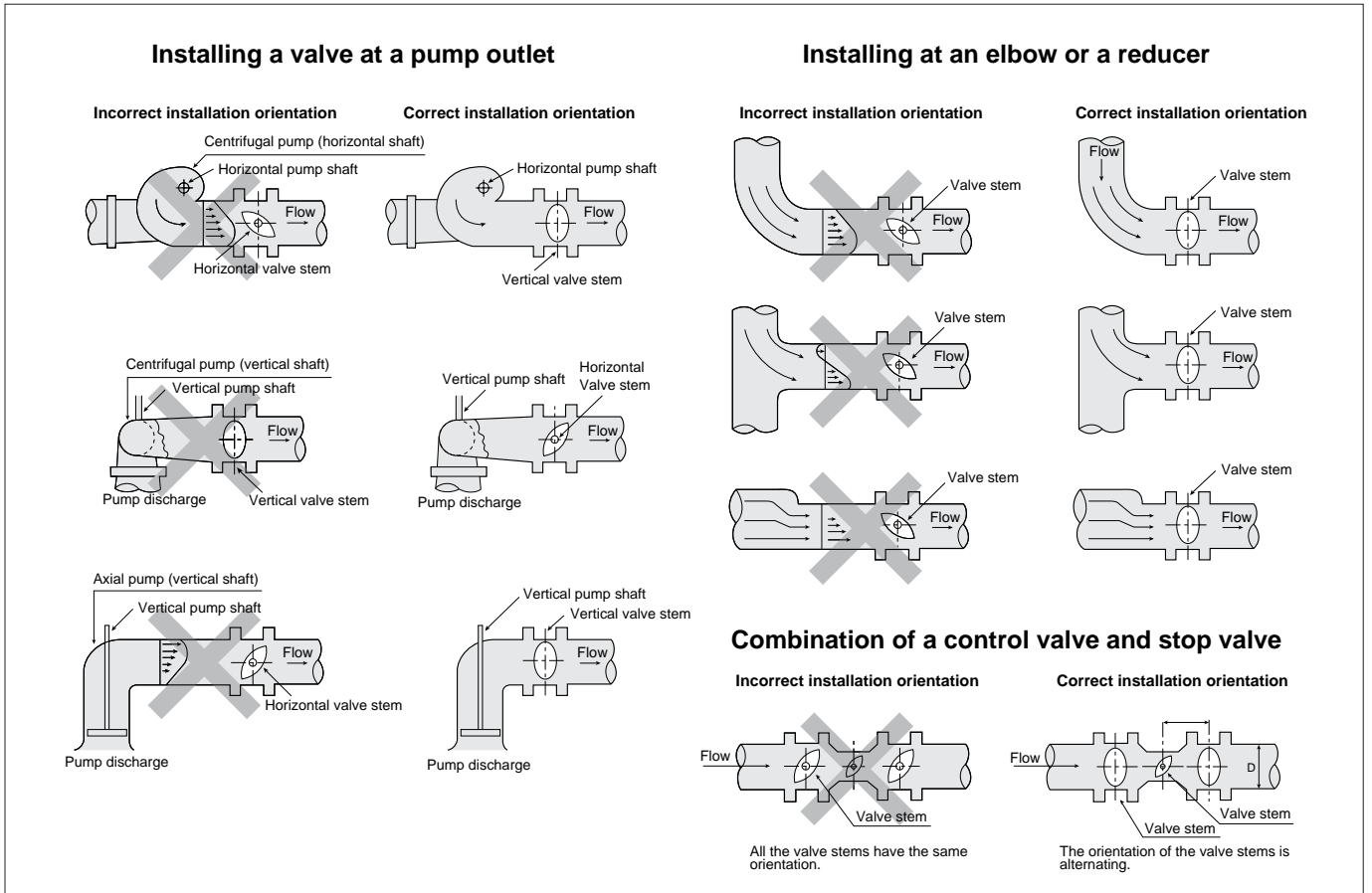

(Fig. 8)

# INSTALLATION PROCEDURE

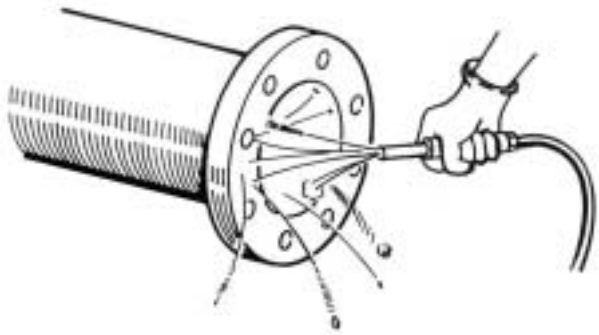

(Fig. 9)

Without setting bolts holes

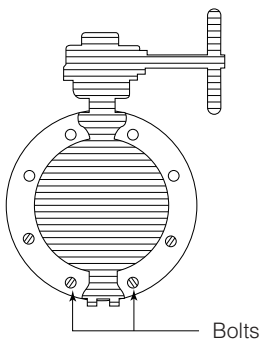

(Fig. 11)

With setting bolt holes

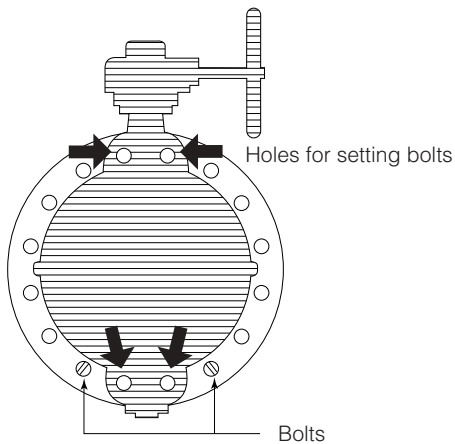

(Fig. 12)

When installing a non-return valve, pump or flexible rubber joint with a butterfly valve, always insert a short pipe in between. Otherwise the disc may hit the other device, resulting in faulty operation.

- (1) Use air purging to clean the flange faces that will contact the valve. If there is rust or some other foreign material sticking to a flange face, clean it with a suitable cleaning fluid (alcohol or neutral detergent, etc.). (Fig. 9)

If possible, install in the piping a short pipe with a face-to-face dimension identical to the butterfly valve and blow into the pipe to completely remove foreign substances.

- (2) During installation or removal, keep the disc slightly open (about 10 ° from the completely shut position).

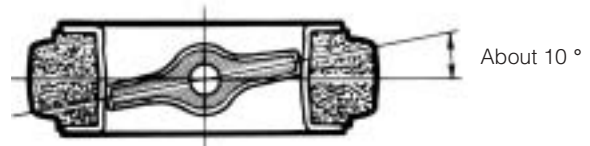

(Fig. 10)

- (3) After aligning the piping, insert a piping bolt into the position in the figure and secure the valve to prevent it from dropping. (Fig. 11) (Fig. 12)

- (4) Place a jack bolt in the position shown in the figure to widen the face-to-face dimension. (If you require, we can supply jack bolts.) Push and widen to make the face-to-face dimension 3 to 5 mm greater than the valve width on each side.

(Fig. 13)

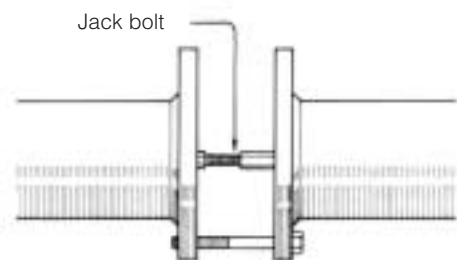

(Fig. 13)

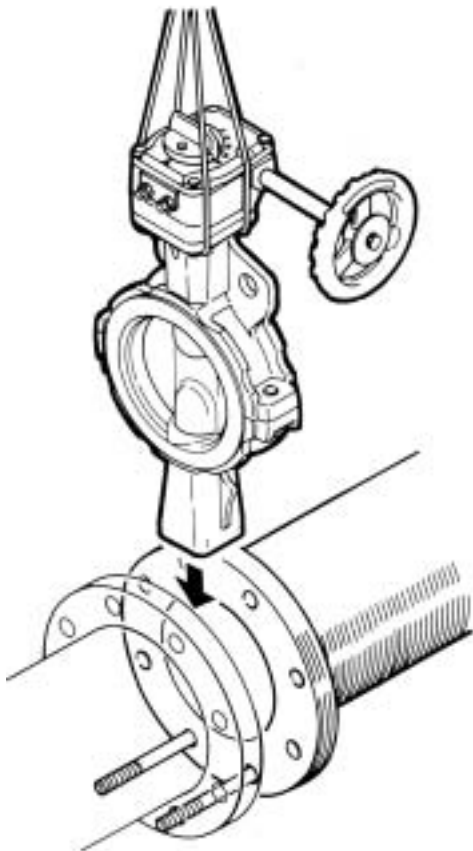

(Fig. 14)

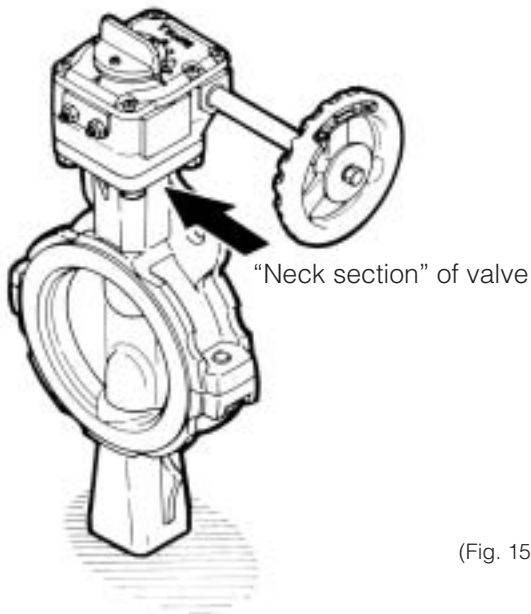

(Fig. 15)

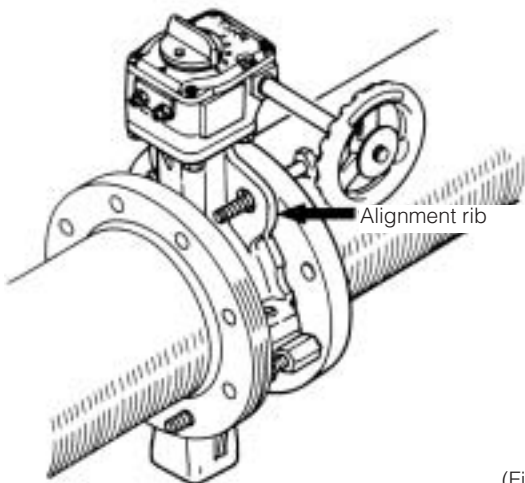

(Fig. 16)

(5) Insert as shown in the diagram, taking care to avoid damaging the seat ring faces of the valve. If the valve is forcibly pushed between the piping edges, the seat rings will be damaged and leakage will result. (Fig. 14)

\*To facilitate installation, suspend the valve with a crane or similar equipment while working. To lift the valve, use nylon string and lift from the “neck ” of the valve if it has no eye bolts or lifting holes. (Fig. 15)

(6) For 841T/842T, insert piping gaskets between the pipe flange faces and the end faces of the valve.

(7) When the valve is completely inserted, insert piping bolts into the piping bolt holes and then insert piping bolts into the remaining flange bolt holes. After removing the jack bolt, align the piping flanges with the valve and then tighten the nuts. (Fig. 16)

(8) After installing all the piping bolts, remove the jack bolt and then gradually tighten the nuts, alternating diagonally, so that they are tightened evenly.

(9) After installing, open and close the valve to verify that the disc does not hit the piping or gaskets.

## HANDLING PRECAUTIONS AFTER INSTALLATION



(Fig. 17)

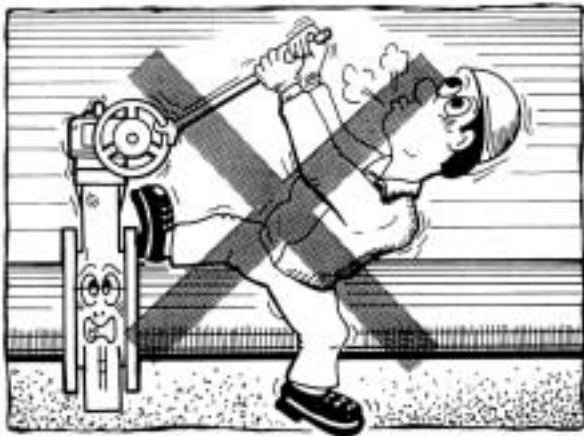

(Fig. 18)

- (1) Before beginning operation, air-purge the outside of the piping and clean the inside of the piping by running water through the piping.
- (2) Prior to operating, increase the internal pressure of the piping and check for possible leakage from the flanges, glands, and bottom cover by employing soapy water or similar. (Fig. 17)
- (3) If leakage is observed from the bottom cover, immediately retighten the bottom cover installation bolts. Alternate and tighten gradually with equal strength to avoid lopsided tightening. If leakage is observed from the flanges or glands, release the internal pressure and remove the valve from the piping. Check that there is nothing wrong with the seat rings.
- (4) Opening and closing operation of the lock lever type and worm gear type must be done by hand. Do not use a pipe on the lever or a Wilky key on the gear handle. Doing so can damage the lever and handle, or break the valve.
- (5) When performing a pressure test (if using a pressure higher than the rated pressure), completely open the valve. Never use a fully closed valve in place of a blind flange. If inserting a blind flange or similar device, take care not to forcibly insert the flange as damage to the seat ring and leakage will result.
- (6) If the system will be not be operated for a prolonged period of time after the piping work is finished, exercise the valve by opening and closing it about once every two weeks.
- (7) Please consult us if the valve is to be used at an opening of 30 °or less.
- (8) After trial operation or operation over a fixed period, retighten the piping bolts and nuts. In particular, leaking from the flange becomes more likely when there are great temperature fluctuations (100 degrees C or higher).

846T and 847T only



### CAUTION

Never remove the C-shape retaining ring ⑯ of the upper stem that appears when you remove the C-shape retaining ring ⑯ used to secure the bottom cover and remove the drive member. If the C-shape retaining ring ⑯ is removed, the spring ⑨ will fly out, which is extremely dangerous.

# INSPECTION AND MAINTENANCE

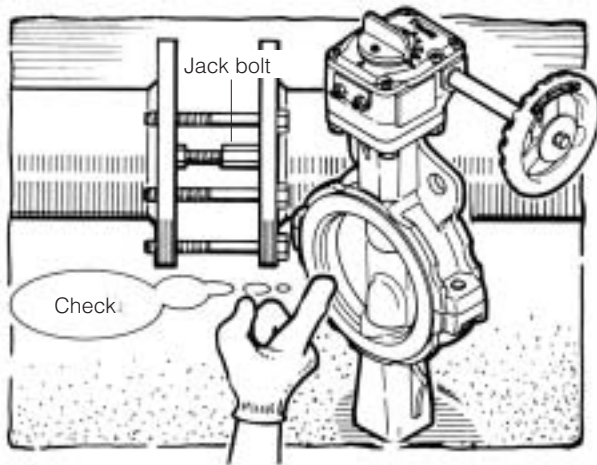

(Fig. 19)

## (1) Periodic inspection

Once a year, please inspect the resin lining material for scratches and the disc and seat ring for abrasion. The gear box and lever unit have been designed to be maintenance-free. (Fig. 19)

## (2) Abnormal operation

Abnormal operation is usually caused by accumulation of foreign material or damage to the seat. If foreign material has accumulated and the disc is in the fully open position, it can be removed by maintaining the fully open position and flushing it out. If that does not work and if the seat is damaged, remove the valve from the piping and inspect it.

## (3) Lubricants

Use lithium-base grease to lubricate the cylinder and use a fluorinated lubricant for the stem. (Be sure to use the ones recommended below.)

Rust preventive agents and Lubricants	Product name (manufacturers)	To be applied to:
Lithium-base grease	Multinoc grease No.2 (Nippon Oil Corporation)	Pneumatic Actuator T-matic
Grease	M ystik JI-6 (Kyodo yushi)	Gear box
Fluorinated lubricant	Daifron grease DG-203 (DAIKIN INDUSTRIES, LTD.)	Stem, bearing, secondary ring, back-up rubber

# VALVE REMOVAL PROCEDURE

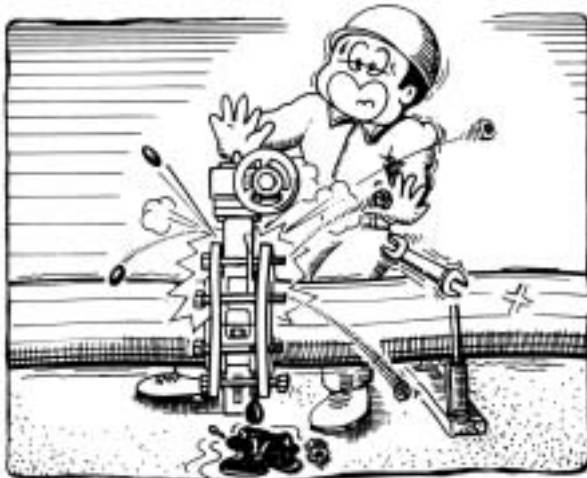

(Fig. 20)

(1) When removing the valve from the piping, make sure that the pressure inside the piping or the temperature have dropped completely.

(2) It is very dangerous to loosen any piping bolts while the piping is under pressure. Be very careful. Also, drain off any residual fluid from the piping. (Fig. 20)

(3) With the disc closed, loosen the piping bolts and nuts. Remove them all except those on the lower side. Remove the valve. Use of a jack bolt in between the flanges will assist in removing the valve more easily.

(4) When used for poisonous or corrosive fluids, be sure to protect yourself sufficiently from any fluid remaining in the valve after removal.

## DISASSEMBLING THE VALVE BODY AND DRIVE MEMBER

### Disassembling the lock lever type

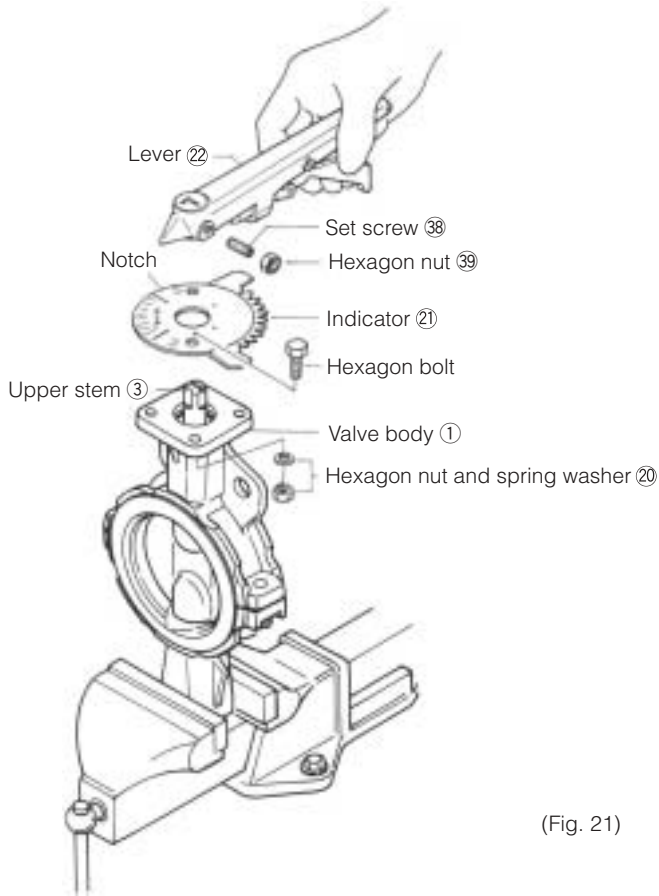

(Fig. 21)

- (1) Open the disc completely.
- (2) Remove the hexagon nut and spring washer (20) that secure the indicator (21) to the valve body (1).
- (3) Remove the set screw (38) and the hexagon nut (39) that secure the lever (22) to the stem (3).
- (4) Hold the valve body (1) with a vise or similar tool and pull the indicator (21) and lever up to remove them. The upper stem (3) remains in the valve body (1). (Fig. 21)

### Disassembling the worm gear type

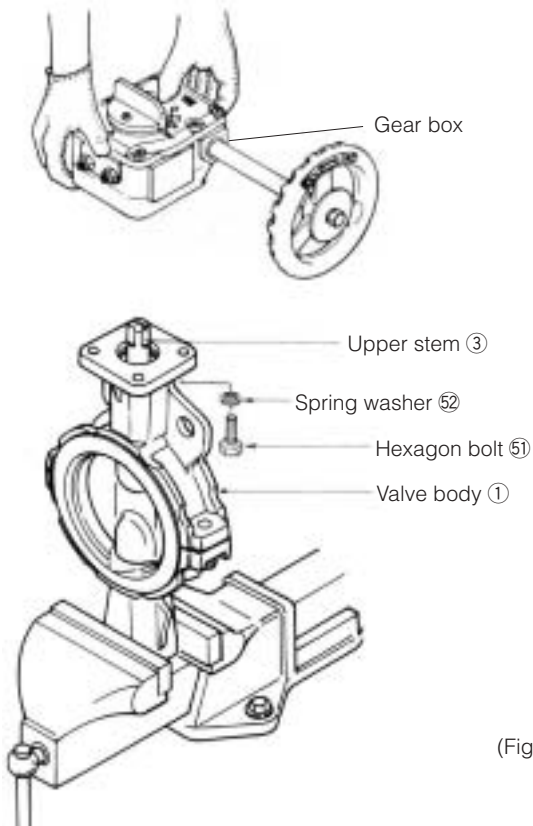

(Fig. 22)

- (1) Open the disc completely.
- (2) Remove the hexagon bolts (51) (4 bolts) that secure the gear box to the valve body (1).
- (3) Hold the valve body (1) with a vise and pull the gear box up to remove it. The upper stem (3) remains in the valve body (1). (Fig. 22)

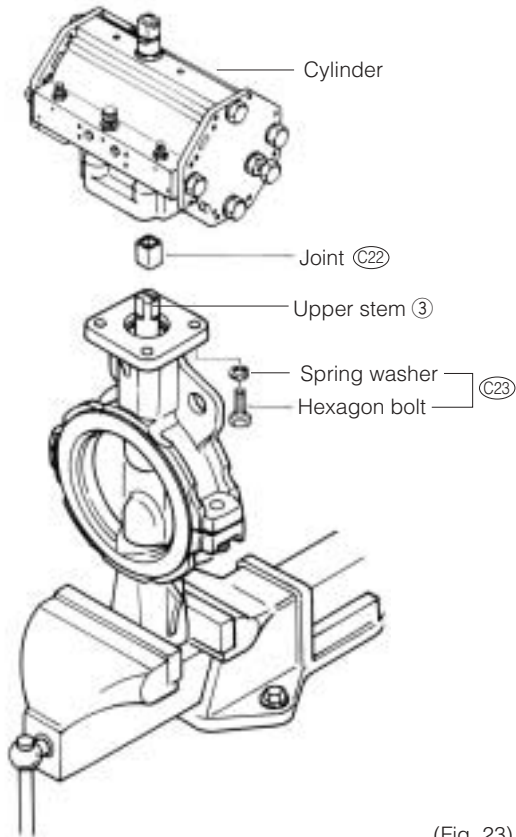

(Fig. 23)

### Disassembling the cylinder (T-matic)

- (1) Loosen the hexagon bolt and spring washer (C23) and then remove the cylinder. (Fig. 23)
- (2) If the joint (C22) still remains on the upper stem (3), remove it.

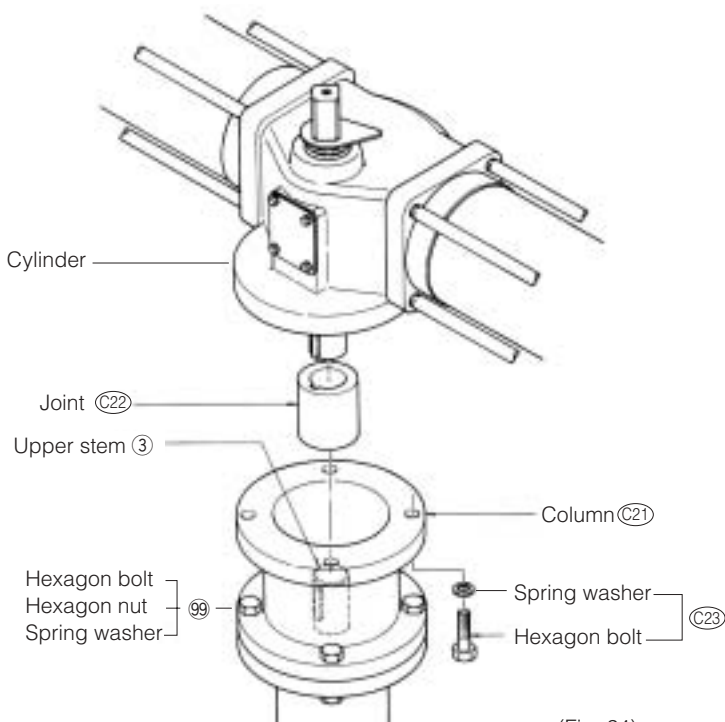

(Fig. 24)

### Disassembling the cylinder (TGA)

- (1) Loosen the hexagon bolt and spring washer (C23) from the column (C21) and then remove the cylinder. (Fig. 24)
- (2) Remove the hexagon bolt, hexagon nut, and spring washer (99), and then remove the column (C21) and joint (C22). (Fig. 24)

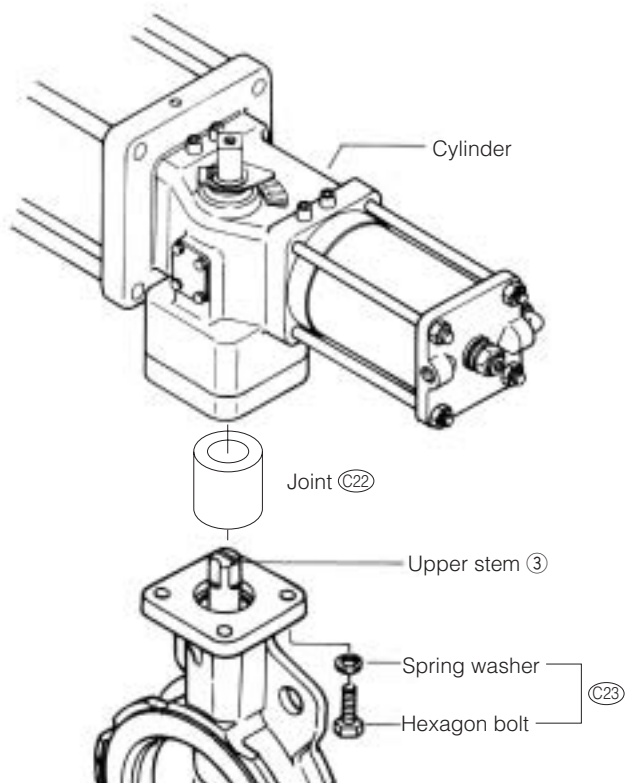

(Fig. 25)

### Disassembling the cylinder (TGS)

- (1) Loosen the hexagon bolt and spring washer (C23) and then remove the cylinder. (Fig. 25)
- (2) If the joint (C22) still remains on the upper stem (3), remove it.

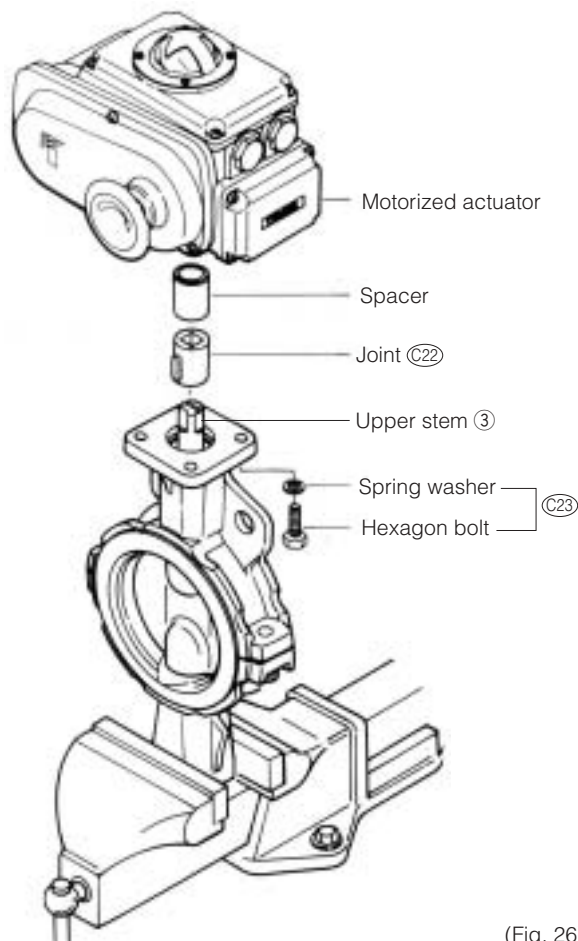

(Fig. 26)

### Removing the motorized actuator (New ELMY)

- (1) Loosen the hexagon bolt and spring washer (C23) and then remove the motorized actuator. (Fig. 26)
- (2) If the joint (C22) and spacer still remain on the upper stem (3), remove them. If the joint and spacer remain on the motorized actuator, take care not to lose them.

To assemble the drive member on the valve, reverse the disassembly procedure.

## DISASSEMBLY AND ASSEMBLY PROCEDURE

When performing periodic inspection or when trouble has occurred due to a worn or damaged seat ring, refer to the expanded view and follow the steps below to disassemble the valve.

### Disassembly Procedure

#### 846T and 847T

The following gives the procedure for 847T. The construction of the 846T is identical except for the fact that its disc and stem can be separated. (The disc and stem can be separated in 847T models whose nominal diameters are 250 mm and 300 mm.)

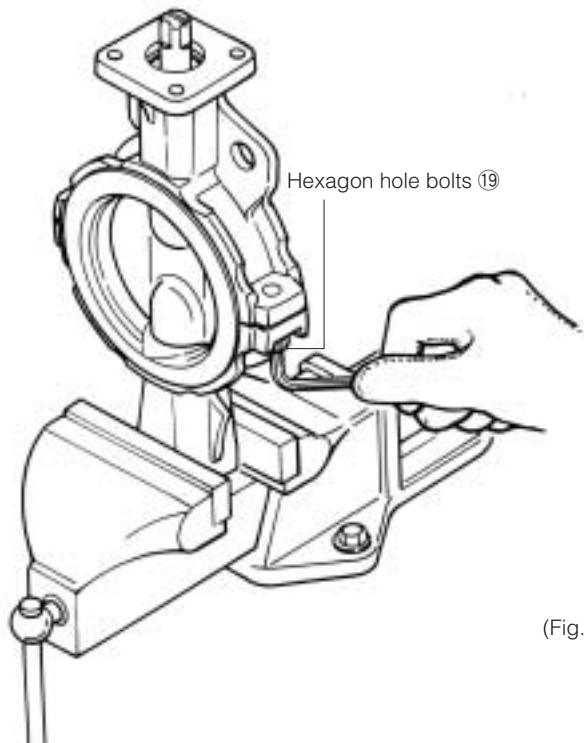

(Fig. 27)

- (1) Even if a valve that was used for dangerous fluids is washed sufficiently, there may still be fluid remaining inside. Therefore, please take sufficient precautions such as by wearing protective gloves.
- (2) Secure the lower part of the valve body firmly with a vice and then loosen the hexagon hole bolts (19). Loosen the right and left bolts evenly, turning each one with 2 to 3 rotations each time. (Fig. 27)
- (3) If you remove the bolts when there is no gap between the upper and lower parts because they are stuck together even after loosening the bolts, the internal spring may cause them to suddenly separate which is very dangerous. As shown in the figure, un-stick the two parts and create a gap that is only the length of the bolts. Once the spring tension has been reduced, remove the bolts. (Fig. 28)
- (4) When the last bolt is removed from the upper part, the force of the spring inside will cause the body to jump up 2 to 3 cm. Therefore, be careful not to get too close to the body with your hands or face.

If there is no gap even after loosening the bolts, tap lightly with a chisel or similar after loosening the bolts 2 or 3 turns.

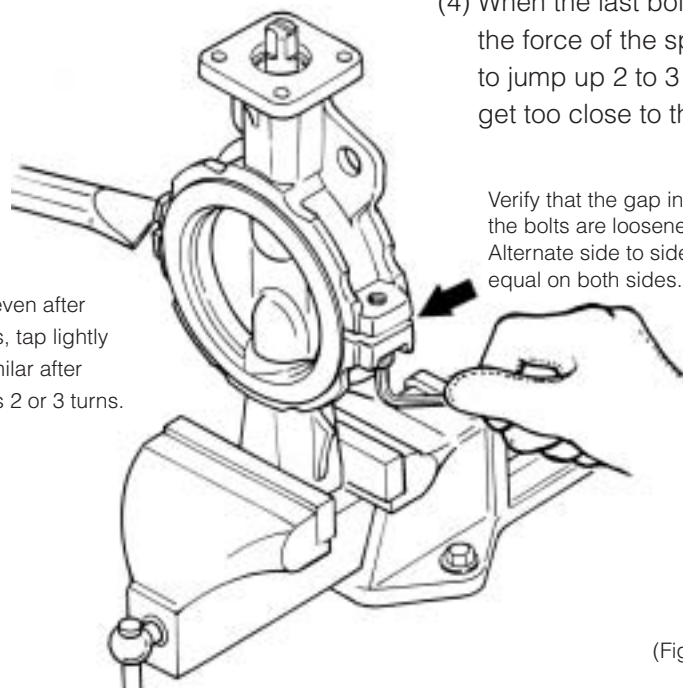

Verify that the gap increases in accordance with the amount the bolts are loosened. Alternate side to side when loosening so that the gap is equal on both sides.

(Fig. 28)

(5) Remove the upper body. The spring retainer ⑫, "O" rings (2 pcs.) ⑰⑱, dust seal ⑪, spring ⑨, bearing ⑦, gland packing ⑩ and secondary ring ⑧ all come off. Parts may stick to the body when it is being removed. Be careful not to lose any of them. (Fig. 29)

(6) Remove the lower body. The bottom cover ⑬, "O" ring ⑰, dust seal ⑪, spring ⑨, bearing ⑦, gland packing ⑩ and secondary ring ⑧ all come off. Be careful not to lose any parts. (Fig. 30)

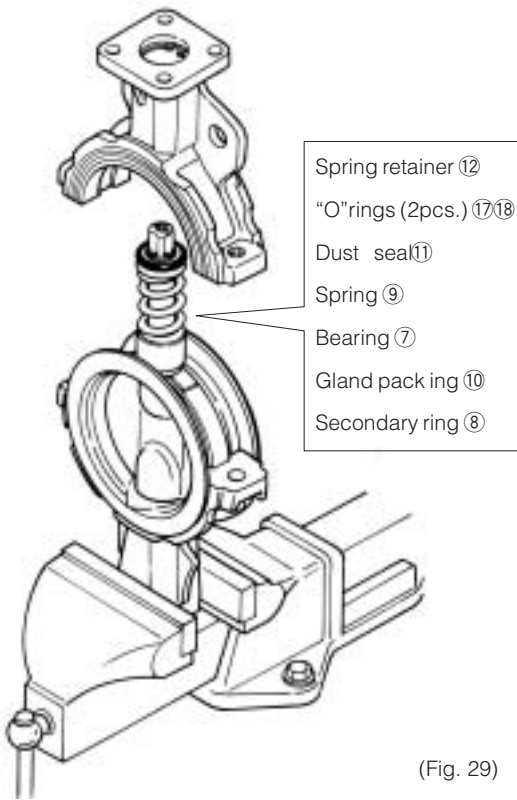

(Fig. 29)

The 50mm type does not have these parts in the lower body.

The seat ring, disc and stem cannot be separated on the 847T. If you need replacement parts, we ship the seat ring, disc and stem as a set.

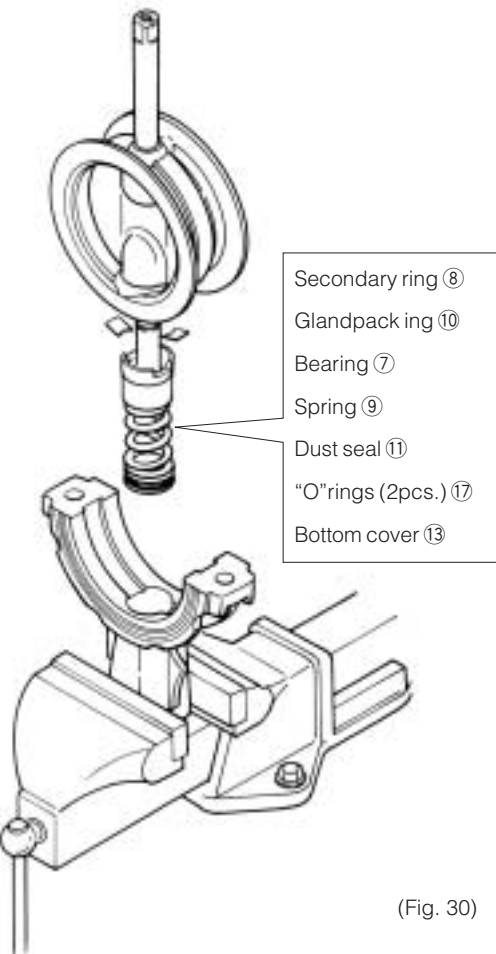

(Fig. 30)

**847T (250 mm and 300 mm)**

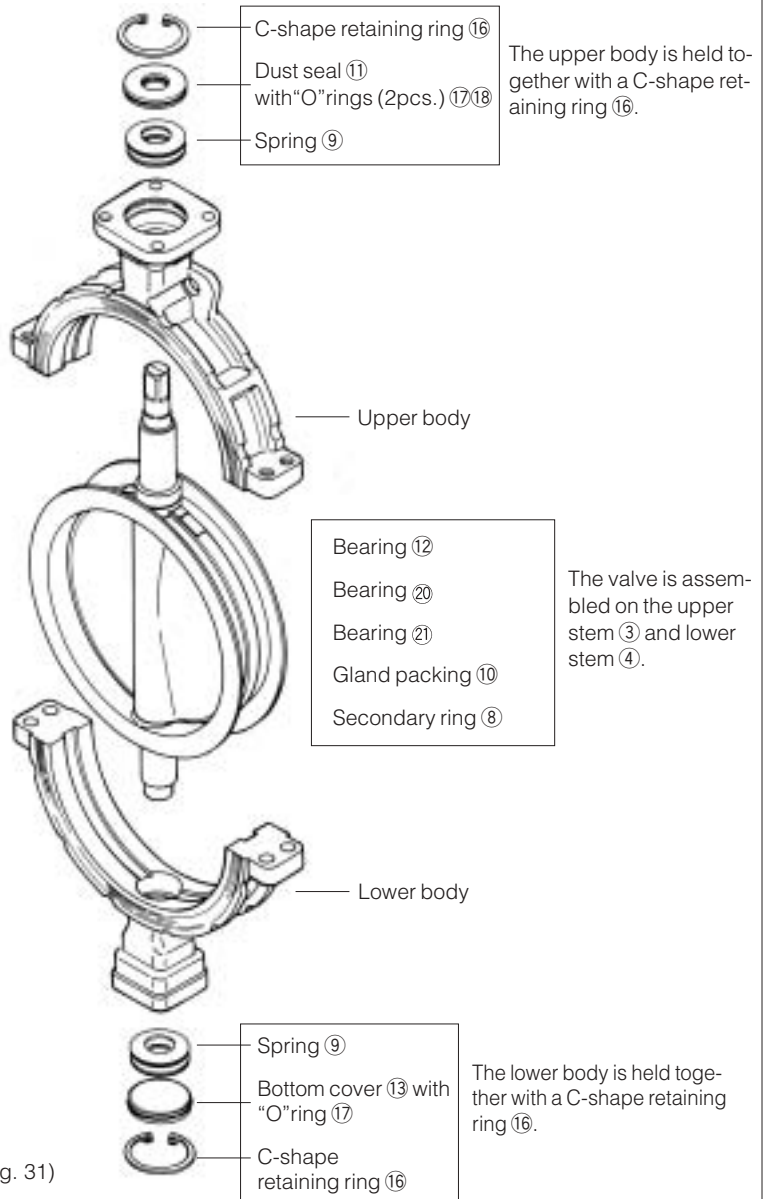

(Fig. 31)

## Assembly Procedure

### 846T and 847T



(Fig. 32)

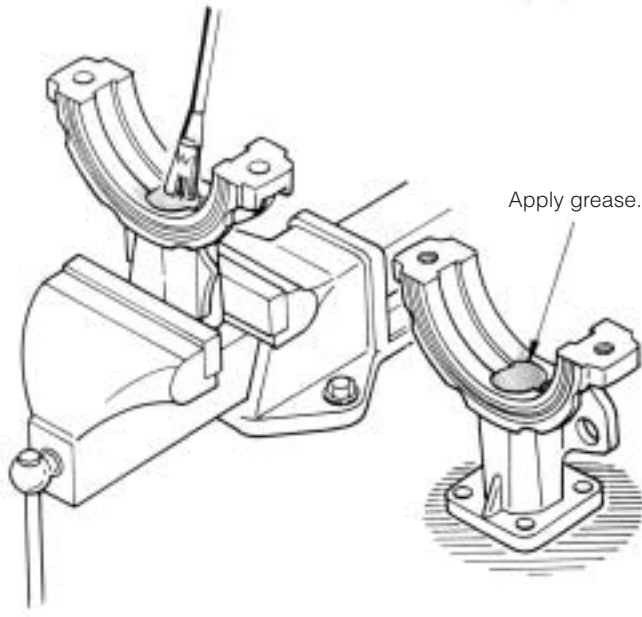

(Fig. 33)

- (1) Before reassembly, clean all parts well using a cleaning fluid such as alcohol or a neutral detergent and make sure that none are damaged or abnormal. (Fig. 32)
- (2) Any parts judged unusable or "O" rings and packing that have deteriorated due to the passage of time (even if not showing signs of wear) should be replaced with new parts.
- (3) Lubricate the upper and lower stem holes of the body (2 locations) with a fluorinated lubricant. Apply thinly and evenly for approximately 20 mm from the internal bore. (Fig. 33)
- (4) Verify that the C-shaped retaining rings ⑯ inserted over the upper and lower bodies have not become deformed or damaged and are firmly seated in their grooves. (Fig. 34)  
If the valve is assembled with them even slightly out of position or deformed, the spring ⑨ could fly out, which is very dangerous.



Never remove the C-shaped retaining rings ⑯ in the two upper and lower locations (1 location on 50 mm type) when the hexagon hole bolts ⑲ are tightened. When removed, the spring ⑨ will fly out, which is extremely dangerous.

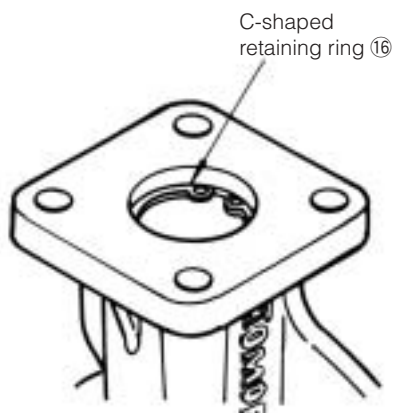

(Fig. 34)

### 847T (250 mm and 300 mm)

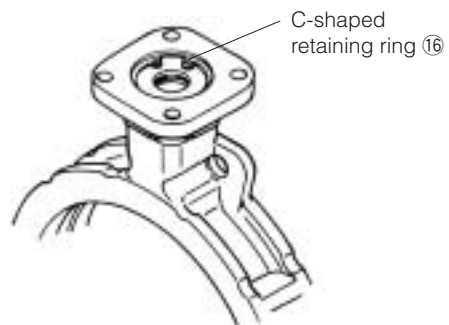

(Fig. 35)

(5) Insert the spring retainer ⑫, "O" ring (large) ⑰, dust seal ⑪ with "O" ring (small) ⑱, spring ⑨ and bearing ⑦ (with bearing ⑳), in that order into the upper body hole. (Fig. 36)

(6) Lubricate the "O" ring ⑰ with fluorinated lubricant.

(7) When assembling, refer to Fig. 37 and Fig. 38 for the correct orientation of the dust seal ⑪ and bearing ⑦.

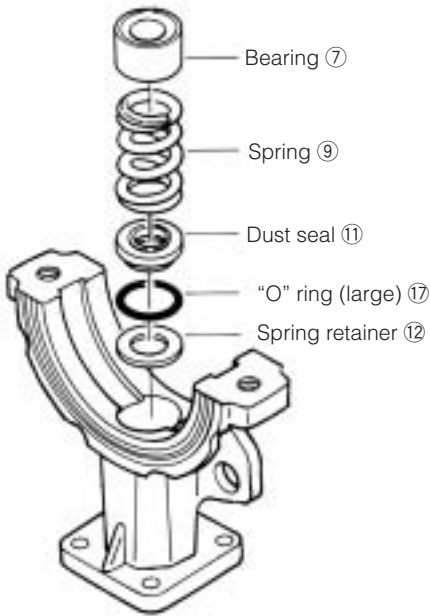

(Fig. 36)

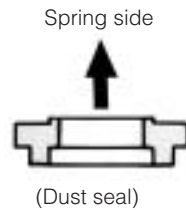

(Fig. 37)

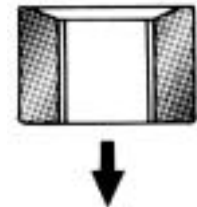

(Bearing)

(Fig. 38)

(8) Insert the secondary ring ⑧ and gland packing ⑩, in that order, onto the upper stem ③. Lubricate the gland packing ⑩ with fluorinated lubricant. (Fig. 39)

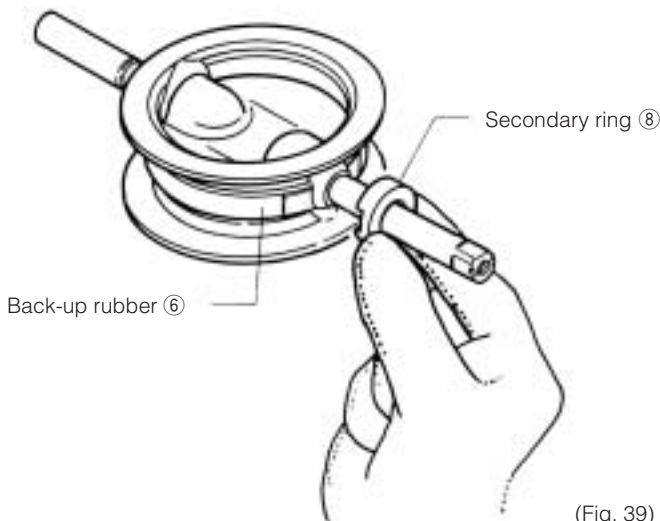

(Fig. 39)

(9) Verify that the grooved part of the secondary ring ⑧ is fitted correctly over the back-up rubber ⑥. Refer to Fig. 40 for the correct orientation of the gland packing ⑩.

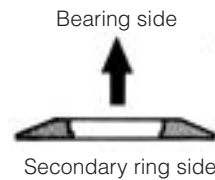

Gland packing

(Fig. 40)

(10) Insert the upper stem into the upper body, which has been assembled with the spring ⑨ and bearing ⑦, etc., and then attach the seat ring ⑤ to the upper body. (Fig. 41)

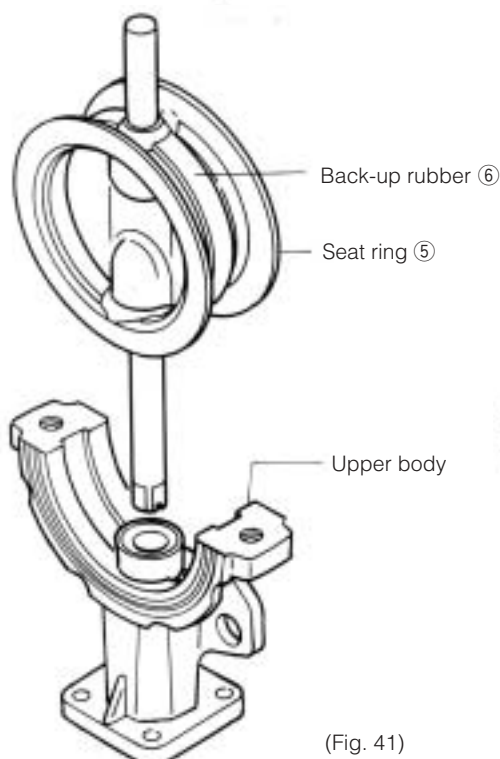

(Fig. 41)

(11) Assemble while verifying that the back-up rubber ⑥ is properly seated in the groove of the upper body. (Fig. 42)

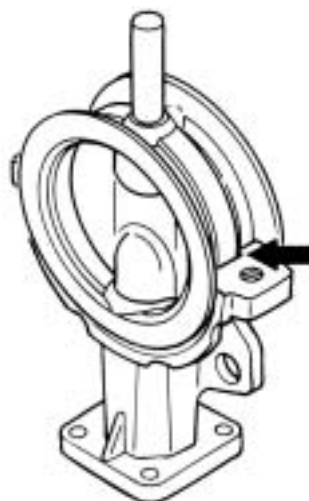

Verify that it is seated properly in the groove.

(Fig. 42)

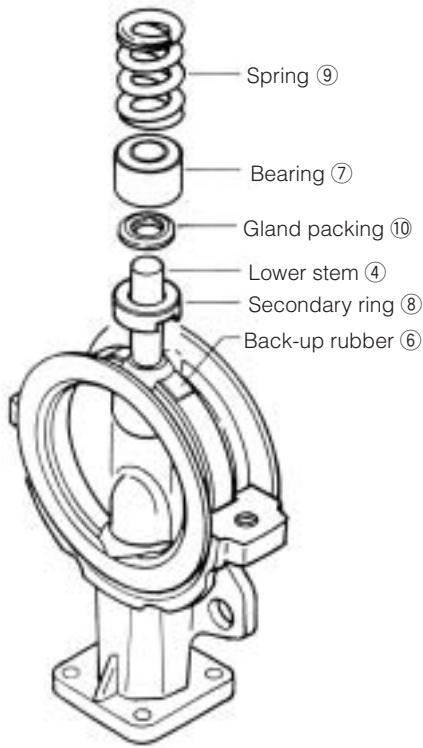

(Fig. 43)

(12) Insert the secondary ring ⑧, bearing ⑦ and spring ⑨, in that order, onto the lower stem ④. (Fig. 43)

(13) Verify that the grooved part of the secondary ring ⑧ is fitted correctly over the back-up rubber ⑥. When assembling, refer to Fig. 38 and Fig. 40 for the correct orientation of the bearing ⑦ and gland packing ⑩. Lubricate the gland packing ⑩ with fluorinated lubricant.

(14) Insert the bottom cover ⑬, “O” ring ⑰, dust seal ⑪, in that order, into the lower body (with C-shaped retaining ring). (Fig. 44)

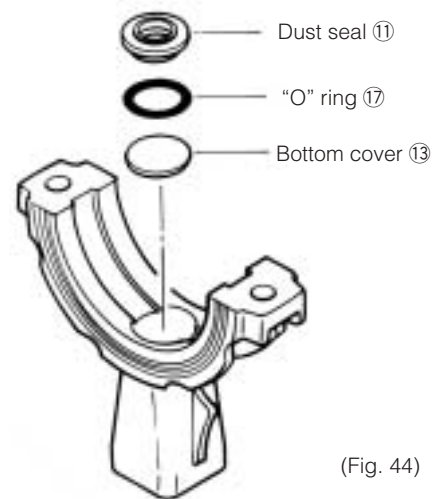

(Fig. 44)

\*Insert the “O” ring ⑰ into the hole of the lower body and verify that it is properly seated as a circle. Next insert the dust seal ⑪, making sure that its orientation is correct (refer to Fig. 37), and then secure after positioning it.

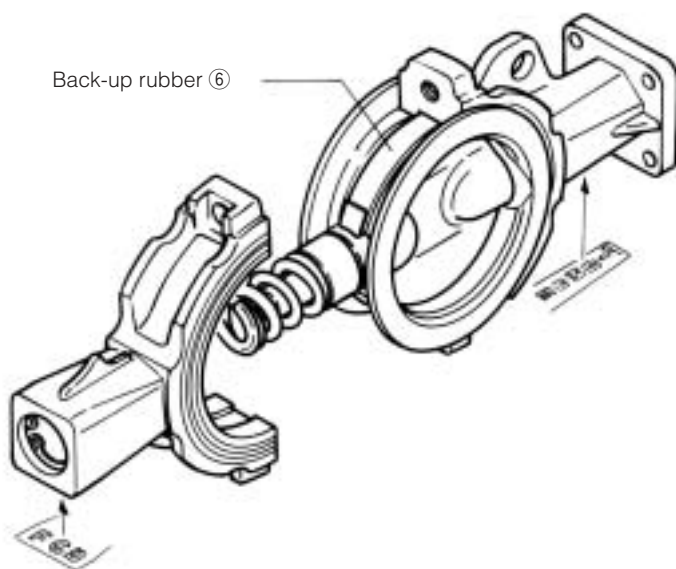

(Fig. 45)

(15) Assemble the upper and lower bodies. When assembling, make sure that the company name lettering on the neck of the upper body is facing the same direction as the lettering for the materials located beneath the lower body. (Fig. 45) (An alignment mark is provided on the sides of the 50 mm type.)

(16) Assemble while verifying that the back-up rubber ⑥ is properly seated in the groove of the lower body. (Fig. 45)

- (17) Set the valve into a valve body tightening jig, and press the upper and lower bodies laterally. Tighten until the side gap is 2 to 3 mm. Temporarily tighten the hexagon hole bolts ⑱ into the right and left bolt holes. (Fig. 46)

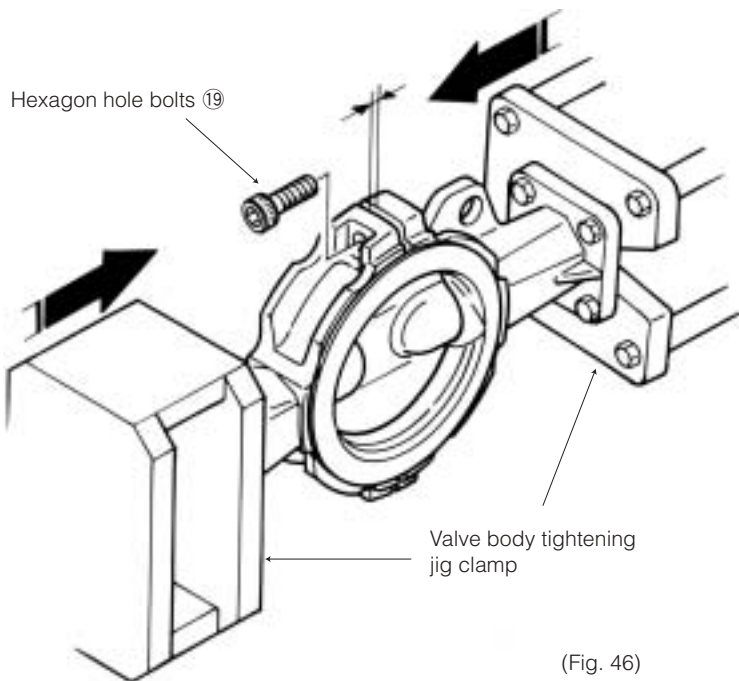

Required clamping power

50mm	1370N( 140kgf )
65mm, 80mm	2750N( 280kgf )
100mm	2940N( 300kgf )
125mm, 150mm	1370N( 140kgf )
200mm	4510N( 460kgf )

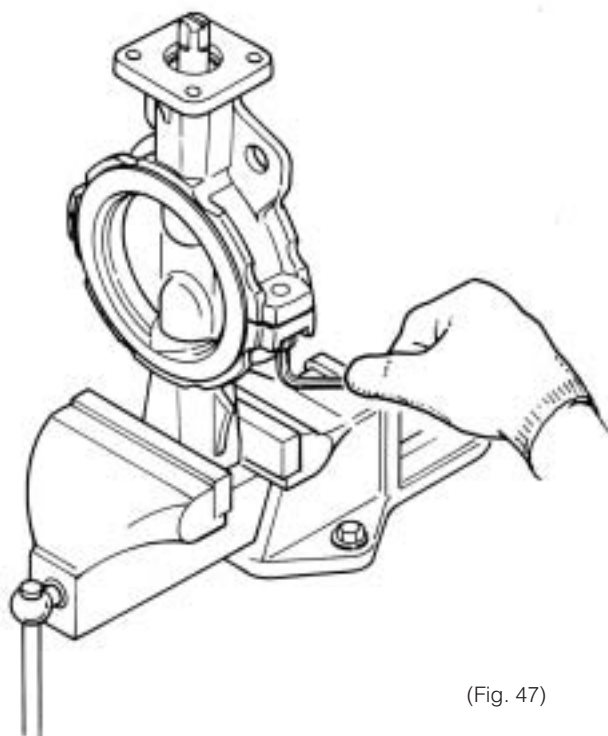

- (18) Verify that the secondary ring ⑧ is seated correctly in the hole of the valve body. Tighten the jig clamp until the upper and lower bodies are tightly together. Tightening too much may cause the valve to deform. Also, when clamped, if you tighten strongly the hexagon hole bolts ⑱ the valve body might slip from the jig, which is dangerous. Therefore, tighten only temporarily.
- (19) Remove the temporarily tightened valve body from the jig and put into a vise. Now tighten the hexagon hole bolts ⑱. (Fig. 47)

\*Before tightening, open and close the disc two or three times. Deviance in the upper and lower bodies will be corrected.

## 847T (250 mm and 300 mm)

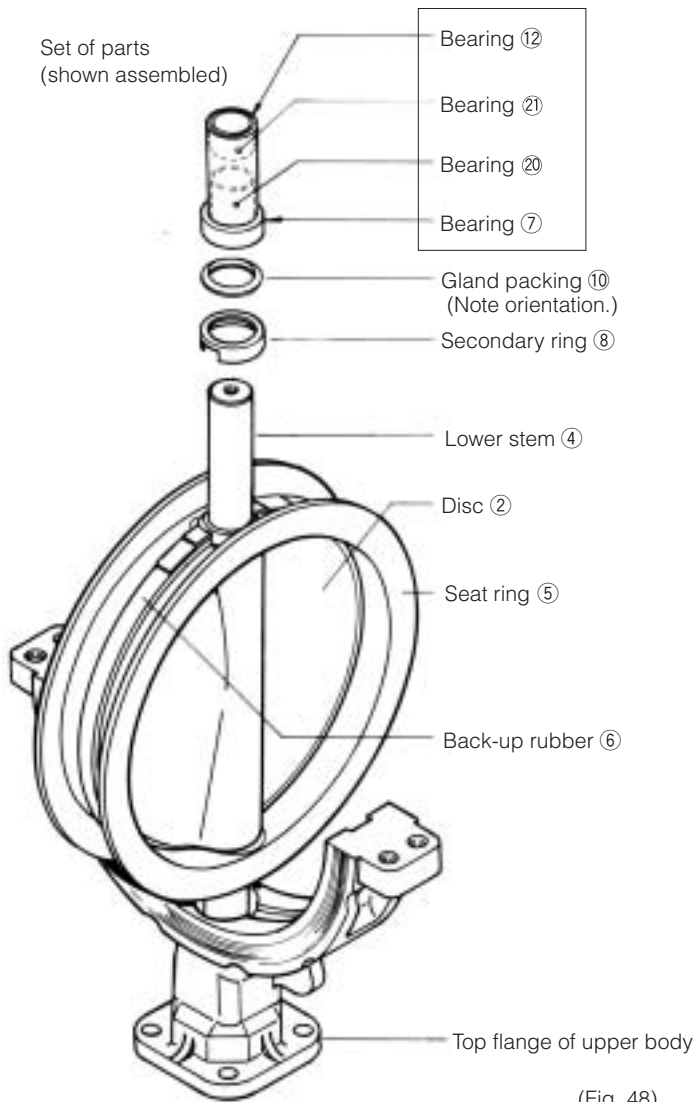

(1) Rest the upper body with the top flange facing down. Create a base by placing bearing 7 and bearing 12 (bearings 20 and 21 together) on the lower stem. So that the lower stem 4 is pointing up, stand the disc 2, seat ring 5 and back-up rubber 6 (the part inserted with the upper and lower stems) and make sure they do not fall over.

(2) Insert the secondary ring 8, gland packing 10, bearing 7 and bearing 12 (bearings 20 and 21 together), in that order, onto the lower stem 4. (Fig. 48)

Refer to Fig. 40 for the correct orientation of the gland packing 10.

(3) Lubricate the outer periphery of the bearing 12 and the stem hole of the lower body with fluorinated lubricant and then attach the lower body. While making sure the inner side of the flange face of the seat ring 5 does not become scratched by the body or anything, push the lower body in so that only one groove of the body flange face can be seen. (Fig. 49) (Fig. 50)

Note: Verify that the back-up rubber 6 is properly seated in the groove on the inner side of the upper body.

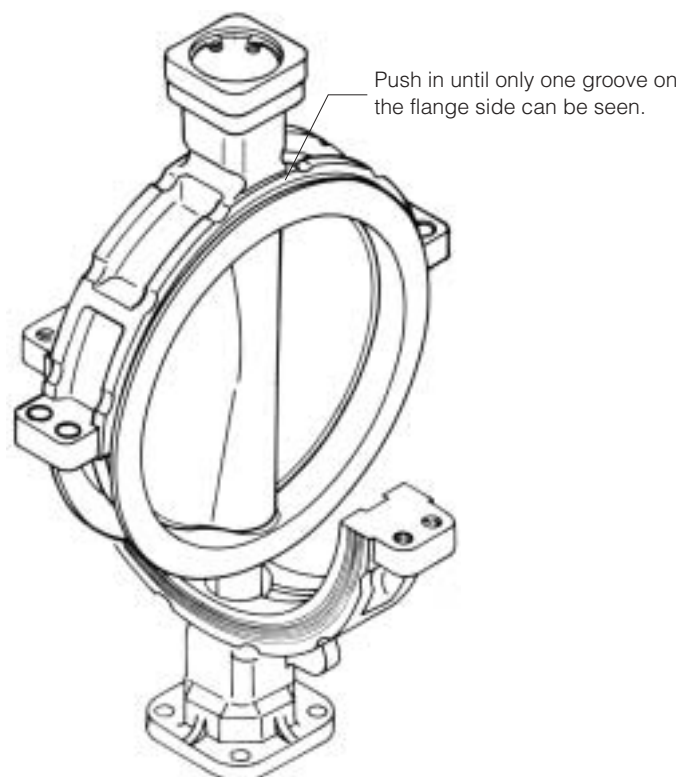
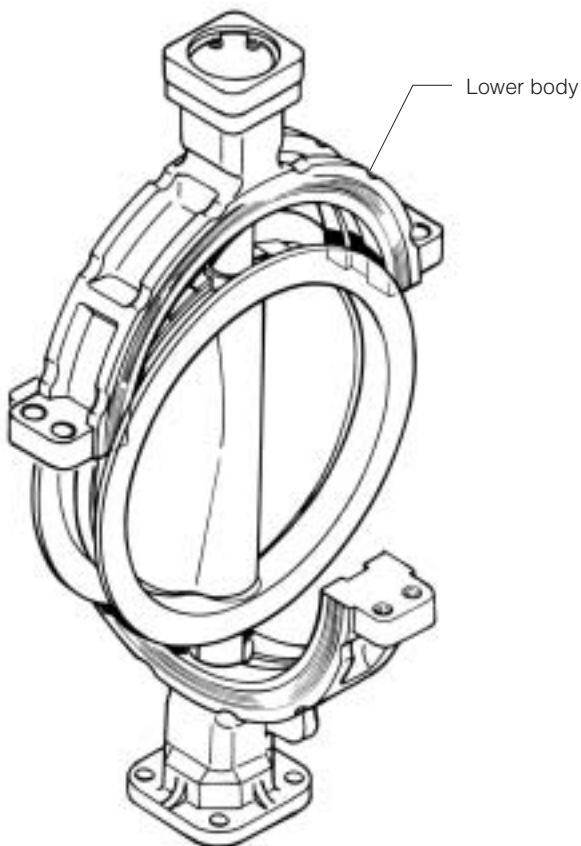

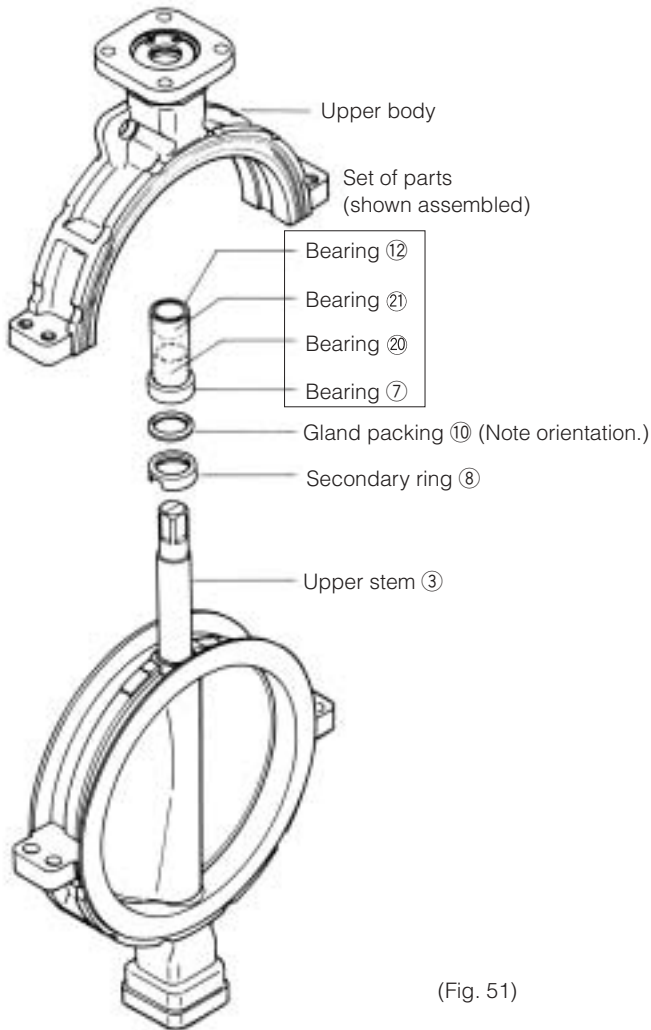

(Fig. 51)

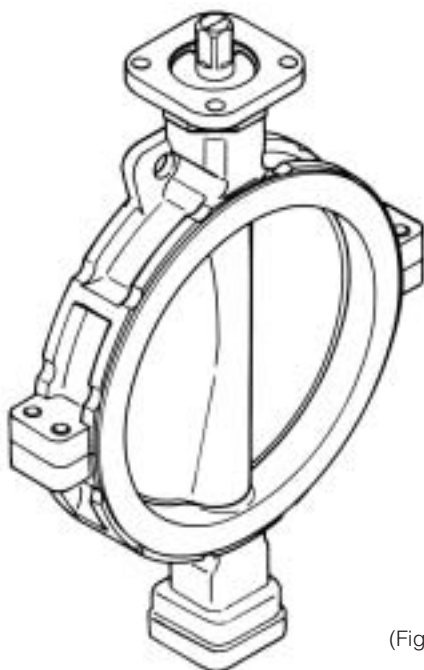

(Fig. 53)

(4) Leaving the upper body as is, remove, as an assembly, the disc 2, seat ring 5 and lower body, and then stand it up with the bottom cover facing down. Insert the secondary ring 8, gland packing 10, bearing 7 and bearing 12 onto the upper stem 3 and then cover this with the upper body. The assembly is heavy, so be careful when handling it. (Fig. 51)

(5) Firmly secure the body with a vise and fully tighten the upper and lower bodies with the hexagon hole bolts 19.

Note: At first, lightly tighten the hexagon hole bolts 19 and fine adjust any deviation in the alignment of the disc by opening and closing it two or three times while simultaneously making adjustments by hitting the body with a plastic hammer. (Fig. 52)

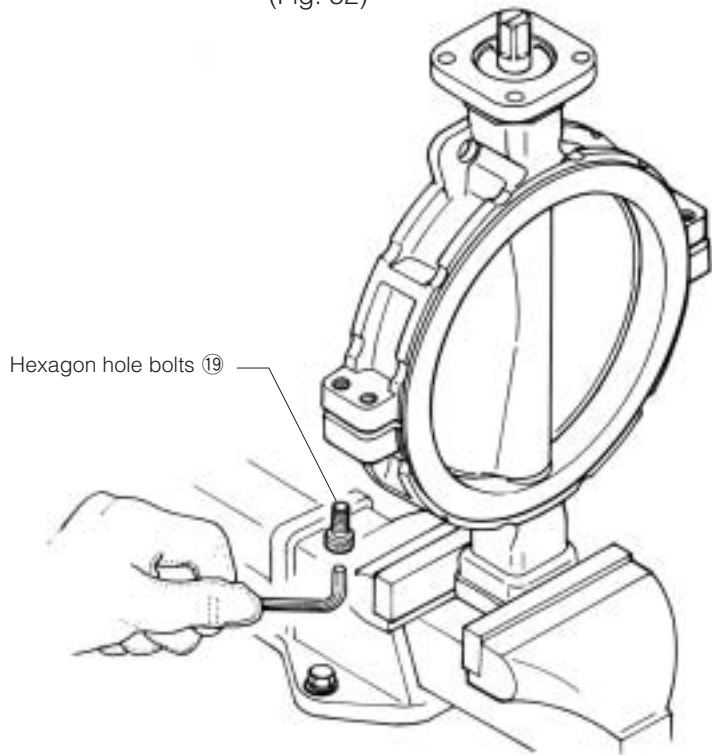

(Fig. 52)

This completes the assembly of the valve body. Verify that no parts were forgotten or assembled incorrectly.

To assemble the drive member on the valve, reverse the disassembly procedure.

## Disassembly Procedure

841T (250 mm to 600 mm)

842T (350 mm to 600 mm)

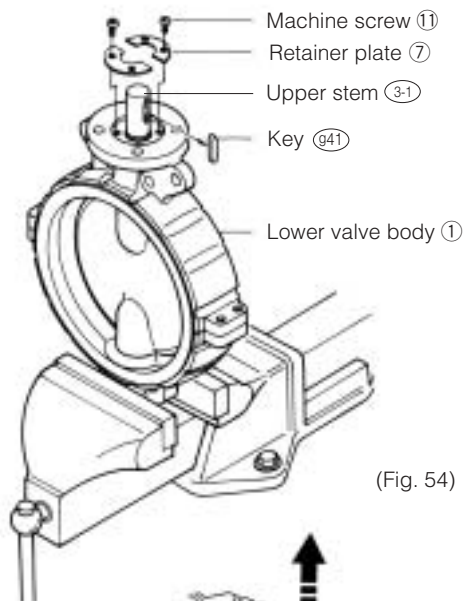

(Fig. 54)



(Fig. 55)

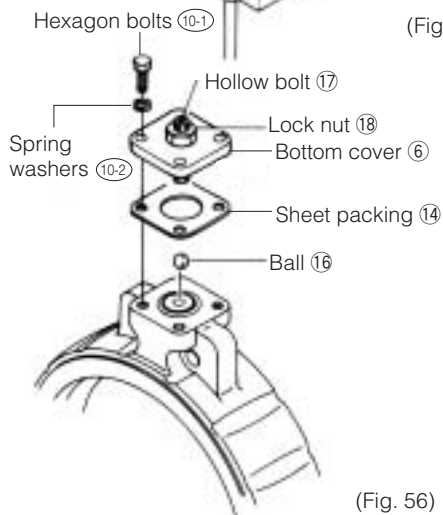

(Fig. 56)

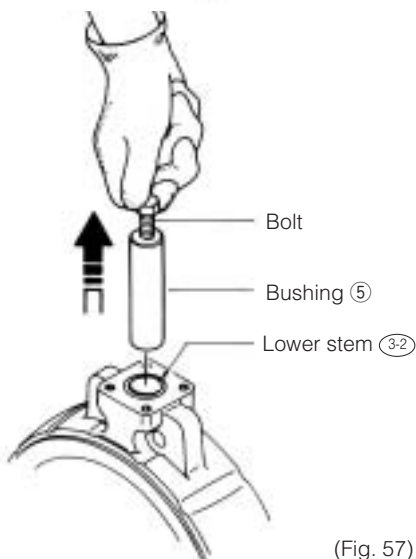

(Fig. 57)

- (1) Hold the lower valve body ① in a vise.
- (2) Remove the key ⑨41 from the stem.
- (3) Remove the machine screw ⑪. The retainer plate ⑦ will come off at the same time when the upper stem ③-1 is pulled out. (Fig. 54)
- (4) Pull out the upper stem ③-1 with a gripping tool. At this time the bushing ④ will not come out at the same time. Do not forget to remove it. (Fig. 55)
- (5) Remove the "O" ring ⑧ (842T only) and "O" ring ⑬ from the upper stem ③-1.
- (6) Remove the lower valve body from the vise, turn it over and then secure the upper body with the vise.
- (7) Remove the hexagon bolts ⑩-1 and spring washers ⑩-2 that secure the bottom cover ⑥ and sheet packing ⑭ from the lower valve body.  
On the 450 mm to 600 mm types, do not remove the hollow bolt ⑰ and lock nut ⑱; leave them attached to the bottom cover ⑥. Take care not to lose the ball ⑰. (Fig. 56)
- (8) Screw a bolt into the tap hole on the lower stem ③-2 and pull out the lower stem ③-2. The bushing ⑤ will not come out at the same time. Do not forget to remove it. (Fig. 57)
- (9) Remove the "O" ring ⑧ from the lower stem ③-2. (842T only)
- (10) Push out and remove the disc ② from the seat ring ⑫.
- (11) Remove the hexagon hole bolt ⑮1 on the side of the valve body, insert a screwdriver into the gap where the right and left sides of the body meet, and remove the lower valve body by pushing it apart. When doing so be careful not to lose the packing ①A that is sandwiched in the right and left sides of the body.
- (12) Insert a screwdriver between the upper valve body and the seat ring ⑫, and remove the seat ring ⑫ from the upper valve body.
- (13) Remove the back-up ring ⑲ and the "O" ring ⑮ (450 mm to 600 mm types only) from the seat ring ⑫.

Assembly Procedure

841T and 842T

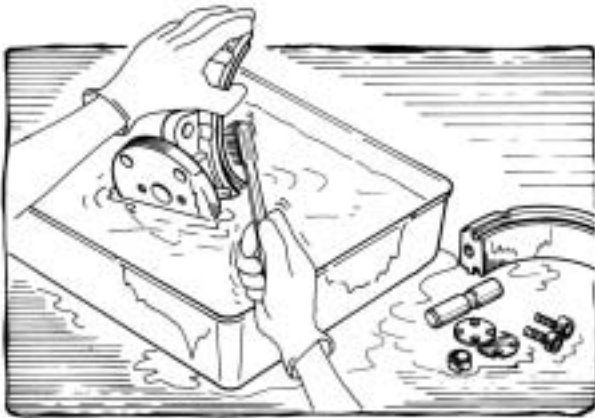

(Fig. 58)

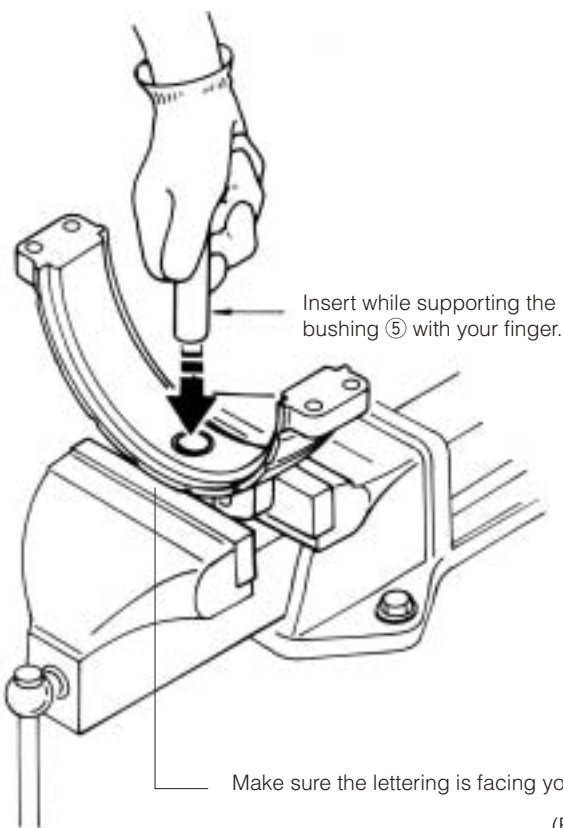

(Fig. 59)

- (1) Before reassembly, clean all parts well using a cleaning fluid such as alcohol or a neutral detergent and make sure that none are damaged or abnormal. (Fig. 58)
- (2) Any parts judged unusable or "O" rings and packing that have deteriorated due to the passage of time (even if not showing signs of wear) should be replaced with new parts.
- (3) Install the sheet packing ⑭ and bottom cover ⑥ to the lower body with the hexagon bolt ⑩-1 and spring washer ⑩-2 .  
For 450 mm to 600 mm types, apply grease to the tip of the hollow bolt ⑰ and use the grease to hold the ball ⑱ in the tip of the hollow bolt ⑰. Install the sheet packing ⑭ and bottom cover ⑥.
- (4) Secure with a vise making sure that the lettering on the lower body is facing you.
- (5) Put the "O" ring ⑧ on the lower stem ③-2 . (842T only)
- (6) Insert the bushing ⑤ in the lower body and insert the lower stem ③-2 . (Fig. 59)  
For 450 mm to 600 mm types, slide the "O" ring ⑮ over the lower stem ③-2 and insert it until it enters the stem hole.

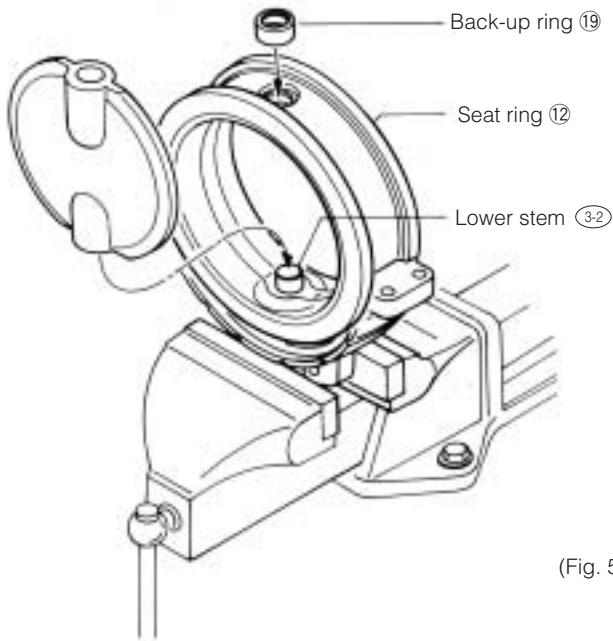

(Fig. 59)

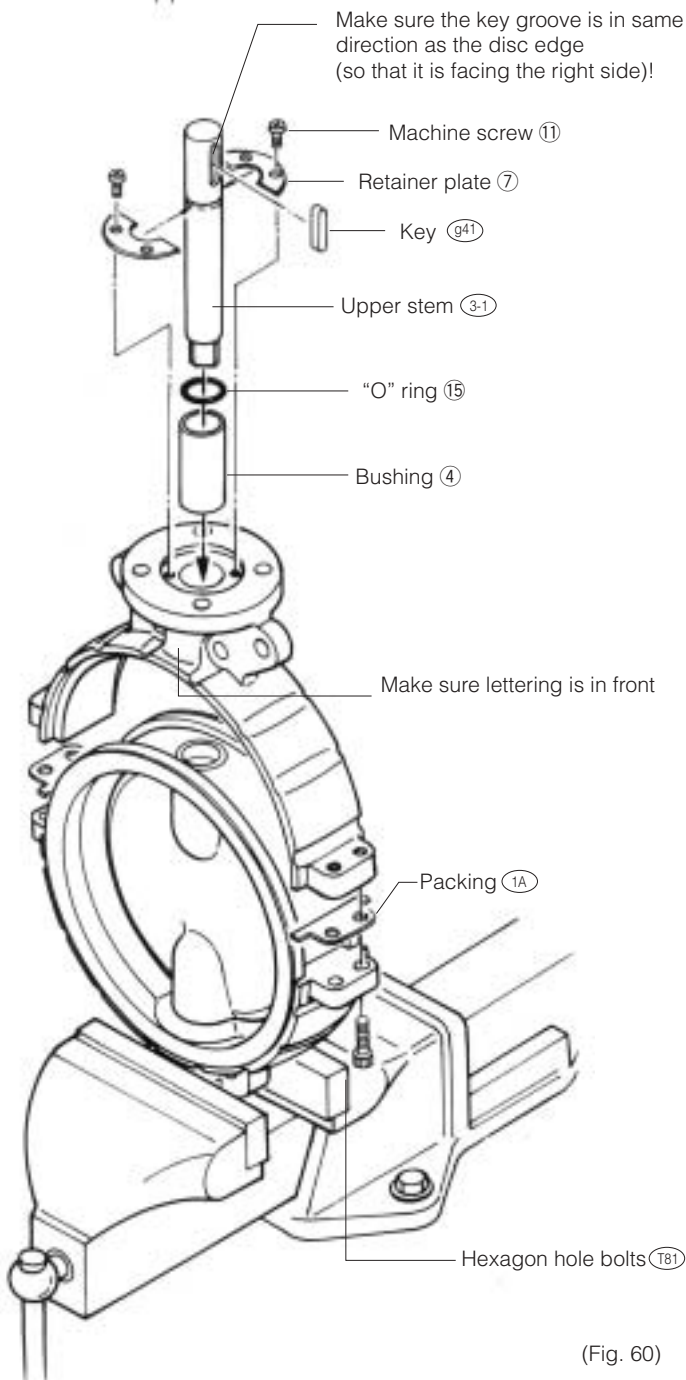

(Fig. 60)

(7) Attach the back-up ring ⑱ to the seat ring ⑫.

(8) Assemble the seat ring ⑫ to the lower stem ③-②. When doing so, insert the seat ring ⑫ until the lower stem ③-② is protruding a bit and use the slightly protruding lower stem ③-② as a guide to insert the disc ②. Press the disk into the lower body together with the seat ring ⑫. (Fig. 59)

(9) Place the upper body onto the seat ring ⑫ so that the lettering is in front.

(10) Put the “O” ring ⑮ on the upper stem ③-①. (842T only)

(11) Insert the “O” ring ⑮ (450 mm to 600 mm types only) and the bushing ④ into the upper body and insert the upper stem ③-①. When doing so, make sure that the key groove is in same direction as the disc edge and that the key groove is facing the right side.

(12) Insert the packing ①A between the surfaces where the upper and lower bodies join on the right and left sides, and tighten with the hexagon hole bolts ⑧1.

(13) Tighten the retainer plate ⑦ with the machine screw ⑪ and insert the key ⑨41. (For 300 mm, 350 mm and 600 mm types, insert after putting the retainer plate ⑦ into the groove of the upper stem ③-①). (Fig. 60)

This completes the assembly of the valve body. Verify that no parts were forgotten or assembled incorrectly.

To assemble the drive member on the valve, reverse the disassembly procedure.

# APPLICABLE PIPE LIST IN CASE OF A AND B

: Installation possible, - : No standard, / : No supported nominal size

Nominal size (mm)	SGP				Sch20				Sch40				VP (Flange)			
	846T	847T	841T	842T	846T	847T	841T	842T	846T	847T	841T	842T	846T	847T	841T	842T
50	/	/	/	/	/	/	/	/	/	/	/	/	/	/	/	/
65	/	/	/	/	/	/	/	/	/	/	/	/	/	/	/	/
80	/	/	/	/	/	/	/	/	/	/	/	/	/	/	/	/
100	/	/	/	/	/	/	/	/	/	/	/	/	/	/	/	/
125	/	/	/	/	/	/	/	/	/	/	/	/	/	/	/	/
150	/	/	/	/	/	/	/	/	/	/	/	/	/	/	/	/
200	/	/	/	/	/	/	/	/	/	/	/	/	/	/	/	/
250	/	/	/	/	/	/	/	/	/	/	/	/	/	/	/	/
300	/	/	/	/	/	/	/	/	/	/	/	/	/	/	/	/
350	/	/	/	/	/	/	/	/	/	/	/	/	/	/	/	/
400	/	/	/	/	/	/	/	/	/	/	/	/	-	-	-	-
450	/	/	/	/	/	/	/	/	/	/	/	/	-	-	-	-
500	/	/	/	/	/	/	/	/	/	/	/	/	-	-	-	-
600	-	-	-	-	/	/	/	/	/	/	/	/	-	-	-	-

: Installation possible, - : No standard, / : No supported nominal size

Nominal size (mm)	Sch10S				Sch20S				Minimum internal diameters of piping (mm)			
	846T	847T	841T	842T	846T	847T	841T	842T	846T	847T	841T	842T
50	/	/	/	/	/	/	/	/	/	34	/	/
65	/	/	/	/	/	/	/	/	51	51	/	/
80	/	/	/	/	/	/	/	/	70	70	/	/
100	/	/	/	/	/	/	/	/	91	91	/	/
125	/	/	/	/	/	/	/	/	118	118	/	/
150	/	/	/	/	/	/	/	/	144	144	/	/
200	/	/	/	/	/	/	/	/	194	194	/	/
250	/	/	/	/	/	/	/	/	246	236	/	/
300	/	/	/	/	/	/	/	/	294	286	/	/
350	-	-	-	-	-	-	-	-	/	/	322	322
400	-	-	-	-	-	-	-	-	/	/	372	372
450	-	-	-	-	-	-	-	-	/	/	421	421
500	-	-	-	-	-	-	-	-	/	/	463	463
600	-	-	-	-	-	-	-	-	/	/	566	566

Remark:  
Butterfly valves are inserted into a pipe that was fitted with the disc when fully open. You are using a pipe or flange that is less than the minimum inner pipe diameter, use is still possible if means are taken such as inserting a spacer between the valve and flange. For details, please consult us.

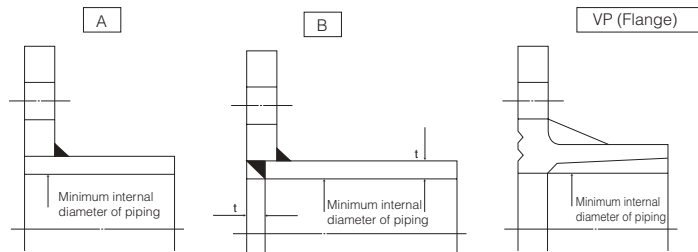

# REQUIRED NUMBER AND SIZE OF PIPING BOLTS

## 847T and 846T Piping bolts and nuts sizes

### Piping bolts sizes

Nominal size		JIS 5K	JIS 10K	ANSI 125Lb/150Lb	DIN NP10, BS4504 PN10
mm	inch	Hexagon bolts and nuts	Hexagon bolts and nuts	Long bolts and nuts	Long bolts and nuts
50	2	4-M12× 90×30	4-M16× 105×40	4-5/8-11UNC× 145×45	4-M16× 125×30
65	2 1/2	4-M12× 90×30	4-M16× 105×40	4-5/8-11UNC× 155×50	4-M16× 125×30
80	3	4-M16× 105×40	8-M16× 110×40	4-5/8-11UNC× 155×50	8-M16× 130×30
100	4	8-M16× 110×40	8-M16× 110×40	8-5/8-11UNC× 165×50	8-M16× 140×35
125	5	8-M16× 110×40	8-M20× 120×50	8-3/4-10UNC× 175×55	8-M16× 140×35
150	6	8-M16× 120×40	8-M20× 130×50	8-3/4-10UNC× 175×55	8-M20× 155×40
200	8	8-M20× 130×50	12-M20× 135×50	8-3/4-10UNC× 175×55	8-M20× 160×40
250	10	12-M20× 135×50	12-M22× 150×60	12-7/8- 9UNC× 215×55	12-M20× 175×40
300	12	12-M20× 150×50	16-M22× 160×60	12-7/8- 9UNC× 215×55	12-M20× 185×40

The bolt lengths are in accordance with JIS and thickness of steel flanges.

Remarks:

\*Please use a hexagon nut with 80% threading.

\*The table above does not apply if the material used is a special material which is not SS400.

## 841T and 842T Piping bolts and nuts sizes

### Piping bolts sizes

Nominal size		JIS 10K		ANSI 125Lb / 150Lb	
mm	inch	Long bolts and nuts	Setting bolts	Long bolts and nuts	Setting bolts
250	10	12-M22× 195×45	—	12-U 7/8×220×55	—
300	12	16-M22× 195×45	—	12-U 7/8×220×55	—
350	14	16-M22× 215×45	—	12-U1 ×260×60	—
400	16	16-M24× 230×50	—	16-U1 ×260×60	—
450	18	16-M24× 245×50	8-M24× 70×54	12-U1 1/8×285×65	8-U1 1/8× 85×70
500	20	16-M24× 265×50	8-M24× 70×54	16-U1 1/8×310×65	8-U1 1/8× 90×70
600	24	20-M30× 300×60	8-M30× 80×66	16-U1 1/4×345×70	8-U1 1/4× 100×70

Remarks:

1. Please use a hexagon nut with 80% threading. For ANSI 125Lb and 150Lb, use heavy nut.

2. A unified screw should have 8 threads per inch if its nominal diameter exceeds 1 inch.

3. The table above does not apply if the material used is a special material which is not SS400.

### Example

Long bolts: 12 - M22 × 195 × 45  
 Quantity      Nominal size (M)      Length of bolt (L)      Effective screw length (S)

Setting bolts : 8 - M24 × 70 × 54  
 (Hexagon bolts)      Quantity      Nominal size (M)      Length of bolt (L)      Effective screw length (S)

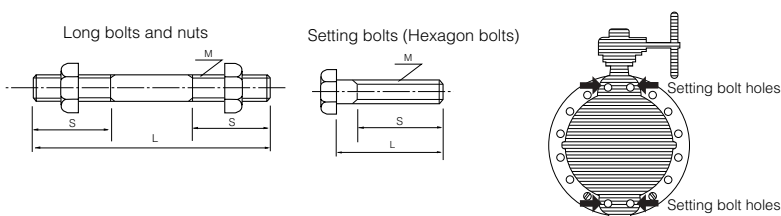

# PIPING GASKET

## 841T/842T Applicable gasket dimensions

Nominal size		841T/842T			
mm	inch	Recommended effective sealing internal diameter (mm)	Max. effective sealing internal diameter (mm)	Minimum internal diameter (mm)	Min. effective sealing external diameter (mm)
250	10	270	270	248	326
300	12	321	321	295	371
350	14	359	359	332	416
400	16	410	410	383	479
450	18	457	457	435	533
500	20	508	508	482	590
600	24	610	610	581	693

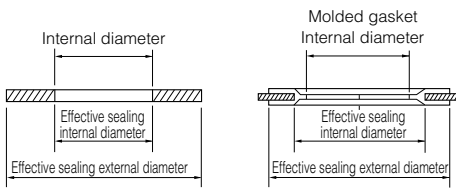

## 841T/842T Applicable standard for piping gasket list

Nominal size		Recommended effective sealing internal diameter (mm)	Sheet gasket		Teflon molded gasket	
mm	inch		JIS10K	ANSI 125Lb/150Lb	JIS10K	ANSI 125Lb/150Lb
250	10	270	×	×	×	×
300	12	321	×	×	×	×
350	14	359	○	○	×	×
400	16	410	○	○	×	×
450	18	457	×	×	×	×
500	20	508	×	×	×	×
600	24	610	×	×	×	×



○ : Standard gasket can be used.

× : Standard gasket cannot be used. (Use one with special dimensions.)

# TROUBLESHOOTING

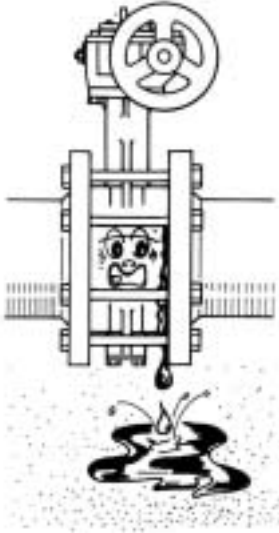
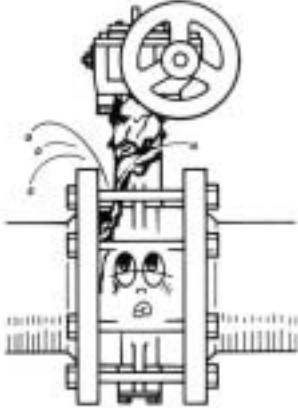
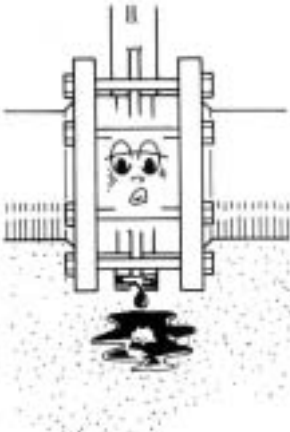
Please refer to the following when there is a problem with a valve.

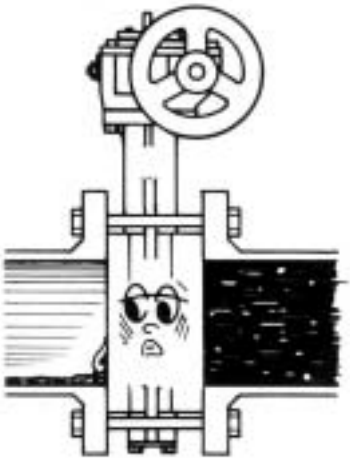
Problem	Cause	Countermeasure
<p data-bbox="177 353 576 416">There is a leak between the body and pipe flange faces.</p> 	<p data-bbox="633 353 1032 416">The piping bolts are loose or they were not tightened evenly.</p>	<p data-bbox="1090 353 1406 416">Loosen the bolts and then retighten them.</p>
	<p data-bbox="633 459 1003 584">The flange gasket face is scratched or there is waste material or other foreign matter adhering.</p>	<p data-bbox="1090 459 1477 584">Remove the body and clean the flange gasket face. Clean the piping flange gasket face and re-install the valve.</p>
	<p data-bbox="633 649 922 680">The valve is misaligned.</p>	<p data-bbox="1090 649 1477 712">Loosen the bolts and realign the valve correctly.</p>
	<p data-bbox="633 754 954 786">Torn or damaged seat ring</p>	<p data-bbox="1090 754 1490 916">Remove the valve body and check the seat ring for signs of tearing or other damage. If any damage is observed, replace the seat ring.</p>
<p data-bbox="177 1025 544 1057">There is a leak from the gland.</p> 	<p data-bbox="633 1025 922 1057">The valve is misaligned.</p>	<p data-bbox="1090 1025 1477 1088">Loosen the bolts and realign the valve correctly.</p>
	<p data-bbox="633 1131 954 1162">Torn or damaged seat ring</p>	<p data-bbox="1090 1131 1490 1292">Remove the valve body and check the seat ring for signs of tearing or other damage. If any damage is observed, replace the seat ring.</p>
	<p data-bbox="633 1310 1011 1373">The gland packing is damaged or has deteriorated.</p>	<p data-bbox="1090 1310 1442 1444">Replace the gland packing. (Refer to "Gland Packing Replacement Procedure" (on page 16.)</p>
<p data-bbox="177 1585 552 1648">There is a leak from the bottom cover.</p> 	<p data-bbox="633 1585 979 1648">The bottom cover installation bolts are loose.</p>	<p data-bbox="1090 1585 1430 1648">Re-tighten the bottom cover installation bolts.</p>
	<p data-bbox="633 1691 1026 1753">The seat packing is damaged or has deteriorated.</p>	<p data-bbox="1090 1691 1477 1753">Replace the seat packing with a new one.</p>
	<p data-bbox="633 1803 922 1834">The valve is misaligned.</p>	<p data-bbox="1090 1803 1477 1865">Loosen the bolts and realign the valve correctly.</p>
	<p data-bbox="633 1915 954 1946">Torn or damaged seat ring</p>	<p data-bbox="1090 1915 1490 2076">Remove the valve body and check the seat ring for signs of tearing or other damage. If any damage is observed, replace the seat ring.</p>

Problem	Cause	Countermeasure
<p>There is leaking from the valve seat.</p> 	<p>The wrong material was selected for the fluid application. (Parts are being corroded.)</p>	<p>Change the material. Please inquire with us regarding selection.</p>
	<p>There is damage to the disc seal or seat ring due to the presence of foreign matter inside the piping.</p>	<p>Replace the disc seal wrapping and the seat ring.</p>
	<p>Movement of disc in the fully closed position.</p>	<p>Adjust the fully closed position of the disc.</p>
	<p>The disc cannot fully close due to insufficient output from the actuator.</p>	<p>Refer to the actuator selection table for correction.</p>
	<p>Fluid specification is not compatible with valve specification. (Specifications have been exceeded.)</p>	<p>Re-check the specifications.</p>
	<p>There is torsion of stem due to an unusual increase in opening/closing torque.</p>	<p>Replace the valve body.</p>
	<p>Movement of disc in fully closed position due to loose actuator installation bolts.</p>	<p>Re-adjust the fully closed disc position by re-tightening the installation bolts.</p>
	<p>Uneven connection between seat ring and disc due to unequal tightening of piping bolts.</p>	<p>Loosen the piping bolts and then re-tighten them.</p>
	<p>Wearing of seat ring due to long period of use.</p>	<p>Replace the seat ring.</p>
<p>Faulty operation (The valve does not work.)</p> 	<p>Prescribed actuator air pressure or voltage not being supplied.</p>	<p>Check by using a pressure gauge, tester, or similar.</p>
	<p>For pneumatic pressure cylinder types, diaphragm of speed controller is stuck in the fully closed position.</p>	<p>Open the diaphragm of the speed controller.</p>
	<p>By-pass valve is in the open position.</p>	<p>Close the by-pass valve.</p>
	<p>Insufficient output due to damaged cylinder parts.</p>	<p>Apply the prescribed pressure and observe functioning. If defective parts are suspected, replace them with new parts.</p>
	<p>Erroneous actuator selection.</p>	<p>Refer to the actuator selection table for correction.</p>
	<p>Increased torque due to presence of foreign matter in the piping.</p>	<p>Keep valve in the fully opened position and flush out the foreign material.</p>







The specifications are subject to change without notice. Please consult us for the latest specifications.  
All copy rights reserved.

**TOMOE VALVE CO.,LTD.** [www.tomoe.co.jp](http://www.tomoe.co.jp)

**Head Office**  
3-11-11 Shinmachi, Nishi-ku, Osaka 550-0013, Japan  
Telephone:81-6-6110-2101/2102/2103      Telefax:81-6-6110-2105/2106

**Overseas Operations**

**TOMOE VALVE LTD.**  
Estuary Road, Queensway Meadows Industrial Estate, Newport, Gwent NP19 4SP U.K.  
Telephone:44-1633-636800      Telefax:44-1633-636801

**TOMOE VALVE S.E.A.PTE.LTD**  
No. 3, Chin Bee Avenue Singapore 619928  
Telephone: 65-68995060      Telefax: 65-68995061